



**PARK CITY BOARD OF ADJUSTMENT MEETING
SUMMIT COUNTY, UTAH
December 12, 2023**

The Board of Adjustment of Park City, Utah, will hold its meeting in person at the Marsac Municipal Building, Council Chambers, at 445 Marsac Avenue, Park City, Utah 84060. Meetings will also be available online with options to listen, watch, or participate virtually. [Click here for more information.](#)

CLOSED SESSION 4:00PM

The Board of Adjustment May Consider a Motion to Enter Into a Closed Session for Specific Purposes Allowed Under the Open and Public Meetings Act (Utah Code Section 52-4-205) to Discuss Deployment of Security Personnel, Devices, or Systems.

REGULAR MEETING CALLED TO ORDER AT 5:00PM

1. ROLL CALL

2. MINUTES APPROVAL

2.A. Consideration to Approve the Board of Adjustment Meeting Minutes from November 7, 2023

3. STAFF AND BOARD COMMUNICATIONS AND DISCLOSURES

4. PUBLIC COMMUNICATIONS

5. REGULAR AGENDA

5.A. **750 River Birch Court - Variance** - Application Withdrawn

5.B. **2724 Creek Drive - Variance** - The Applicant Requests a Variance to the Front Setback Requirements in the Single-Family Zoning District to Extend the Existing Front-Facing Garage. PL-23-05853
(A) Public Input; (B) Action

6. ADJOURNMENT

Pursuant to the Americans with Disabilities Act, individuals needing special accommodations during the meeting should notify the Planning Department at 435-615-5060 or planning@parkcity.org at least 24 hours prior to the meeting.

***Parking is available at no charge for Council meeting attendees who park in the China Bridge parking structure.**



**PARK CITY MUNICIPAL CORPORATION
BOARD OF ADJUSTMENT MEETING
MINUTES OF NOVEMBER 7, 2023**

BOARD MEMBERS IN ATTENDANCE: Ruth Gezelius-Chair, Stefanie Wilson, Jennifer Franklin, Beth Armstrong, John Stafsholt

STAFF: Rebecca Ward, Assistant Planning Director; Lillian Zollinger, City Planner; Jaron Ehlers, Planning Technician; Mark Harrington, Senior City Attorney

1. MEETING CALLED TO ORDER AT 5:00 p.m.

Chair Ruth Gezelius called the meeting to order at 5:00 p.m.

2. ROLL CALL

Chair Gezelius noted by roll call the attending Board Members, adding that they constituted a quorum. She recalled that Board Member Mary Wintzer was excused, however might join via Zoom.

3. MINUTES APPROVAL

A. Consideration to Approve the Board of Adjustment Meeting Minutes from June 20, 2023.

MOTION: Board Member John Stafsholt moved to APPROVE the Board of Adjustment Meeting Minutes from June 20, 2023, as presented. Board Member Beth Armstrong seconded the motion.

VOTE: The motion passed with the unanimous consent of the Board.

4. STAFF AND BOARD COMMUNICATIONS AND DISCLOSURES

There were no Staff or Board Communications or Disclosures.

5. PUBLIC COMMUNICATIONS

No comments were submitted.

6. REGULAR AGENDA

A. Parcels PC-850-2 and PC-850-3 – Variance – The Applicant Requests a Variance to the Required Lot Size in the Estate Zoning District to Combine Two Lots to Construct a Single-Family Dwelling. PL-23-05797.

City Planner, Lillian Zollinger reported that the two parcels involved in this Variance request are located on King Road as one travels through and out the back of the Alice Claim Subdivision. She presented an aerial view with the parcels highlighted in green. She identified an unfinished road that was highlighted in yellow on the aerial view. She noted the Staff questions outlined in the Staff Report regarding access to the Lots. The applicant provided more information and would provide additional details later in the meeting. Both Lots are located in the Estate Zoning District and the Sensitive Land Overlay ("SLO").

Planner Zollinger reported that Parcel PC-850-2 is 1.44 acres in size and Parcel PC-850-3 is 0.71 acres for a total of 2.15 acres. The applicants were requesting to combine both Lots because they are separately substandard in the Estate Zoning District. A Variance was requested because even when combined, the single Lot will be substandard. She noted that Parcel PC 850-2 complies with the Lot Width requirement for the Estate Zoning District; however, by itself, Parcel 850-3 does not comply. If the Board of Adjustment grants the Variance, the Applicants will still be required to record a Plat to create a single Lot. The Applicants will also be required to confirm and prove access to the Lot and will be required to perform a Sensitive Land Overlay analysis. As detailed in the Staff Report, Planner Zollinger noted the concern expressed about Steep Slopes and indicated that it would be addressed in future approvals.

Staff recommended that the Board of Adjustment review the proposal, open a public hearing, and direct Staff to draft a Final Action Letter for approval or denial, and return with Findings on December 12, 2023. A representative for the Applicants was present to respond to questions.

Board Member Wilson mentioned that the Staff Report states that the Lots are developable until they are moved into the Estate Zone. She asked what the prior zoning was for these parcels. Planner Zollinger was not sure of the prior zoning but whatever zone the parcels were in previously did not have a three-acre lot size requirement. Board Member Wilson asked if the parcels were zoned for residential lots. Planner Zollinger could not provide an answer.

Board Member Stafsholt noted the reference in the Staff Report that the parcels were never noticed, and the change occurred around 1981. He observed that this was a claim made by the Applicants without historical documentation. Board Member Wilson mentioned the Applicants' claim that the Lots were largely surrounded by land that could not be built on; however, when she pulled up the zoning map, the surrounding area

appeared to be Estate zoned. She asked if the property could potentially be subdivided and used to build homes on three-acre lots. Planner Zollinger stated that was possible, but it would depend on which parcel is being referenced. The closest Subdivision is Alice Claim, which has subdivided lots. Board Member Wilson noted that the land to the north and south of the parcels is zoned Estate and wondered if it could be developed. Planner Zollinger responded that if the surrounding lots are three acres in size, they would be developable.

Board Member Stafsholt noted that the Applicants stated that the lots around them are not developable, so they would not be able to add to the 2.15 acres to 3 acres. He noted that to the southwest and the south if they were zoned Estate, he did not see why that would be the case unless there are Steep Slopes. Chair Gezelius asked about the slope. While the information states that there is a slope there is no more specific information defining it.

Nick Frost identified himself as an attorney in Park City who represented the Applicants, Kathy Dubie and Kerry Spalding, who are cousins. Each own their respective parcels. The first time he appeared before a municipal body was a Board of Adjustment Meeting in Michigan. He described his experience. Mr. Frost provided history related to the parcels and presented a graphic showing the family tree of ownership and chain of title. He reported that Maggie Barnicott came to the United States from Switzerland, and her husband, Charles, was from England. Ms. Barnicott originally procured the Alice Claim and he provided for the Staff Report the 1903 letter regarding that Claim. The Barnicotts had six children, one of whom was Della Rhea. Della Rhea had three daughters, Marjorie, Bonnie, and Ina. Ina sold her interest in the Claim to Marjorie. He noted that both Marjorie and Bonnie have daughters, Kathy and Kerry, whom he represents.

Mr. Frost reported that George Westervelt drafted the 1903 letter to Maggie Barnicott. Mr. Westervelt is a Salt Lake City and Park City attorney whose law partner is Lee White, who also served as City Attorney for a time. With regard to the Variance request, Mr. Frost stated that it was a request for equity. Specifically, for this meeting, they were looking at the density issue. In addition to access, Steep Slope, and Sensitive Land Overlay requirements, the land likely had contaminated soils and other issues they would face down the road. However, they had done quite a bit of research and the family kept meticulous records of these Parcels so they have a strong reasonable belief that they would be able to satisfy these requirements.

Mr. Frost explained that the Alice Claim Subdivision was a very extensive project that went through a lot of approvals. For this Variance request, the Applicants would likely acquiesce to the same Conditions of Approval and would cross those bridges when they got to them. He next addressed the Variance elements and reiterated that this was a request for equity. He praised Planner Zollinger's statements in the Staff Report that laid out the elements required to be satisfied for a Variance. He stated the Applicants' responses to satisfy the elements were honest and thoughtful.

Mr. Frost stated that a recurring idea is equity and each of the Applicants' responses centered on the owners being able to use the land that had been in the family for a long time. He had been involved in a number of Variance requests and acknowledged that some are harder than others. The hardest element to satisfy was that "substantial justice is being performed." He noted that the more difficult requests are those seeking an oversized hot tub in a Setback or building a home that is six to seven feet higher than those around it. With those types of requests, it is more difficult to argue "substantial justice." He felt that in this instance, substantial justice was self-evident because this family is simply trying to use their land.

Mr. Frost addressed the questions about the land that surrounds the parcels. One of the first things they did was look at the surrounding land to see if they could carve off some portion of land from either the south or the west. The land to the immediate east is open space owned by Alice Claim Subdivision, as is the land immediately to the north. Talisker Land Holding Company owns the land to the north, which is a platted Lot. He commented that it might have been part of the Flagstaff Agreement and is not developable. In any event, the Applicants had not been able to contact the owners to determine if they were interested in selling it. Talisker also owns property in the area being held as Mining Claims, which generally do not show up on land use maps. Even if they were able to carve some of that land, the Applicants expressed concern as to whether it would be recognized by the City as developable land. Based on the Flagstaff Agreement, he believed that it would likely not be developable. He believed that based on the research and discussion it was not probable that the Applicants could purchase any of the surrounding land.

With regard to prior zoning, Mr. Frost reported that the research pointed to this land being previously zoned Historic Residential-1 ("HR-1"). The Applicants would prefer the land remain Estate, as opposed to rezoning. One reason was that Estate zoning requirements are more stringent. The land would also be next to another Estate zone, which is one of the Lots in Alice Claim. The two parcels would, therefore, be consistent with one another. Mr. Frost reiterated that the request was for density. He recognized that an approval tonight would not stand on its own and would be subject to numerous subsequent approvals. They hoped for the opportunity to go before the City and work with Staff to see if something could be done with this land. He opined that at the very least, they could satisfy the requirements for a Variance and requested the Board consider granting the request.

Board Member Stafsholt asked Mr. Frost to expand on the statements regarding the zoning change in the 1980s. Mr. Frost stated that based on the research, the land was zoned HR-1 in 1981. They found an Ordinance that became effective in January 1984 that changed that to the Estate zone. He stated that no one in the family had documentation or notifications of that zoning change and stressed that the family kept meticulous records dating back to the early 1900s.

Mr. Frost added that Summit County recognized "Lot of Record" status based on equity principles. That means that if a lot were created in the previous zoning before a specific date, it would retain the previous zoning even after subsequent zoning. He mentioned for illustrative purposes that most of the Lots around the Old Ranch Road area were much smaller than 20 acres but considered Lots of Record that they enjoy whatever zoning they had when they were created.

With regard to the Applicants' request for equity, Board Member Stafsholt highlighted the point that the zoning was changed 39 years ago but not brought up until now despite the fact that a lot of improvements had occurred. He noted that the Applicants were now looking to possibly benefit from those improvements that occurred over the last 17 years. He added that he was pretty familiar with Alice Claim.

Mr. Frost could not speak to why they did not build something 30 to 40 years ago, adding that the property stayed in the same family and were not remnant parcels nor a situation the Applicants created. He recognized that someone would have to be the last to build, and they were not trying to take advantage of Alice Claim. To the extent they could cooperate and pay for part of those improvements that could be done as well.

Board Member Wilson referenced the survey provided by the Applicants that showed the owners of the Lots around the parcels and it appeared that King Development Group owned the Lot to the north. She referenced the language regarding No Disturbance and asked if that was dedicated Open Space required of the Alice Claim developer. Mr. Frost agreed that was his understanding. He anticipated that the City would require the same for the Applicants' Lots and would designate the Building Envelope in order to restrict the remaining space to be neither buildable nor developable.

With regard to the land to the south, Board Member Wilson noted it appeared to be Mining Claims, and she assumed that land was not usable. Mr. Frost confirmed that was his understanding based on the research. In response to Board Member Wilson's inquiry regarding the 1981 Zoning Map, Mr. Frost stated he had the Zoning Map and could send it to the Board.

Board Member Stafsholt stated that history was a big part of Applicants' presentation, and it sounded as though the family owned the Alice Claim Mine. Mr. Frost confirmed that the family owns the Mining Claim. Board Member Stafsholt understood that the family sold off the other piece that is currently owned by King Development. Mr. Frost confirmed and stated that he included some of those deeds in their report. He also confirmed the family sold off the piece that was now the Alice Claim Subdivision and kept this piece.

Board Member Stafsholt noted that the family kept meticulous records during the 17 years of contentious discussions and the extensive remediation at Alice Claim but did not raise this issue until now. He pointed out that the family owned the piece that is now the Alice Claim Subdivision, and they could have worked with the owner to do this subdivision and have developable Lots throughout that period. He noted it was a very public situation for

a very long time. Mr. Frost was aware of the situation and stated that it took place in the early 1980s when the family kept the parcels and sold the remainder of the land. He stressed that it was not a recent event, and it would have been the Applicants' mothers who would have been involved in those events. He further explained that during the 1970s that area was still being discussed and it was contentious for other reasons. He did not believe they were part of the Alice Claim Subdivision, nor did the developer approach them. He questioned whether the Applicants' mothers had the opportunity to participate.

Board Member Stafsholt noted that after 17 years, the Alice Claim approvals came in 2022 for the nine Lots and the four Open Space parcels. Mr. Frost stated the records showed that that took place in 1981 and the Applicants had not tried to develop these parcels. He was confident that the Applicants were not approached about developing these parcels and did not believe there was an opportunity to join. Board Member Stafsholt noted the 14 years of soil work done on the other lands and asked if any soil work had been done on these parcels. Mr. Frost did not think any soil work had been done, but he recognized the extent of the soil work on Alice Claim and the Applicants recognized what would be needed on these parcels. He noted, however, that that would be addressed as part of future approvals.

In response to an inquiry regarding when the Applicants became the owners of these parcels, Mr. Frost did not have the information with him. He stated one of them was in Marjorie's Trust and he assumed that Applicant Spalding would have become the Trustee upon Marjorie's death. He guessed that probably occurred in the 1990s or early 2000s and it was likely the same with Applicant Dubie.

Board Member Franklin noted the screen was showing various maps and asked for clarification on those boundary lines. She also noted that page 42 of the Packet showed the slope analysis, which she felt connected to the questions regarding the slope. She requested some clarification of the location of the parcels on page 42 of the Packet. Mr. Frost stated that page 42 was the Alice Claim Slope Map taken from the Staff Reports for that project. He pointed to the approximate location of the Lots on the presented image.

Planner Zollinger presented the 1981 Zoning Map and pointed out the approximate locations of the parcels and the zoning designations. She stated the belief was that prior to this time, it was zoned Forest Estate and changed over to Estate in 1981. She also presented the current zoning map that showed the current HR-1 boundary, which includes part of the Alice Claim Subdivision.

Chair Gezelius recalled the action to create the Estate Zone on Steep Slopes at the higher elevations in Old Town in the 1980s and noted there was great concern about the scale of development moving up the mountain. She mentioned avalanche, runoff, access, and density, and stated there was great concern regarding moving the HR-1 zoning up the hill, given the density that existed in the valley of Old Town. She added that at that time,

it was deemed desirable to create a three-acre minimum in the Estate Zone to preclude that level of development on the hillsides in the Historic District.

Board Member Stafsholt added that the final Alice Claim Subdivision started out quite differently than the ultimate nine Lots and four Open Space parcels that were approved. He stated it began as a mini-Park Meadows, and echoed Chair Gezelius' comments regarding the concerns about geotechnical, geophysical, runoff, and the like. He stated that Alice Claim turned out to be more of an HR-1 with one parcel that is three acres. He stressed that was not the development that King Development had in mind in the beginning.

There was discussion about potentially going back to the previous zoning, and Mr. Frost stated the legal possibility might exist, however, it was not something they had explored. He stated the Applicants were not trying to force a right; rather, this application was a plea for equity. He added that Summit County had that equitable principle built into its Code that he outlined for illustrative purposes only.

Board Member Wilson noted the comment that Applicants would rather have it zoned Estate because it was more stringent. She wondered if there was an option. Mr. Frost stated that the comment was made as opposed to trying to rezone the property to something else or to call it back to HR-1. He stressed the Applicants were not trying to rezone the property and noted they just wanted to build one residence on the property if approved.

Chair Gezelius opened the public hearing.

Assistant Planning Director, Rebecca Ward reported that there were participants online who wished to speak. Chair Gezelius acknowledged that those on Zoom could provide their comments.

Kerry Spalding clarified that her mother lives in Indiana and is very far from the property. When she inherited the land, she had no idea what was going on with the surrounding area. In response to comments as to why they waited so long, she stated she was never approached by anyone about the property and had no idea what was going on with the Alice Claim Subdivision. She stated that Kathy Dubie was in the same boat. Speaker Spalding reported that she lives in Illinois and Ms. Dubie lives in Indiana.

There was no further public comment. The public hearing was closed.

Chair Gezelius stated that Staff was looking for direction regarding either denial or approval of the Variance, or whether further information was needed. She noted the Packet did not include Conclusions of Law or Conditions of Approval, and those would be provided in a subsequent meeting. She suggested the Board move through the five criteria they must find to be in harmony with the request in order to grant the Variance.

She invited Board Member Armstrong to provide her thoughts and conclusions on the first criterion.

Board Member Armstrong stated that based on the first criterion, unreasonable hardship, she believed that a hardship exists when someone owns the property and never received information on changes being made. She felt that if someone does not live here and no one advises of the changes, then the owner would have no way of knowing about these changes, which created a hardship.

Board Member Franklin was torn on the information provided to the Board because there appeared to be some gaps in information. Coming into this, she did not feel that the request met the hardship criterion; however, she was concerned about some of the things they discussed during this meeting.

Board Member Wilson felt the Applicants met the hardship requirement. She added that private property rights were something she believed in, and the Applicants should be able to gain value from their property by developing it. She clarified that this did not necessarily indicate how she would vote, but for this particular criterion, she felt there was a hardship for the Applicants to not be able to utilize their property.

Board Member Stafsholt agreed there was a hardship to the Applicants. He also stated that notification had never stood up and added that he was currently working on two matters on which he was never notified as an individual owner within 300 feet, but it did not seem to hold up.

Chair Gezelius commented that while the City had responsibility for notice, the individual property owner also had a responsibility to follow up and pay attention to what was happening with their real estate investment. She did not believe there was any way to ascertain accurately whether notice was attempted, not delivered, not provided, or not read or processed. She felt it was a moot point. She stressed that the fact was that the property was changed to Estate zoning with a three-acre minimum 40 years ago in order to stop and limit the development of small parcels of land on these sensitive hillsides and Steep Slopes. She added that many people would call these inaccessible properties.

With regard to the second criterion, which is special circumstances attached to this property that do not generally apply to properties in the same zone, Board Member Stafsholt expressed that all the properties in the same zone had the same circumstances applied. In this case, he did not feel there were special circumstances for these two Lots compared to anything else in the Estate Zone.

Board Member Wilson assumed that when the Estate Zone was created, it was subsequently subdivided into three-acre parcels. Planner Zollinger stated that parcels exist and then as the City acquires them zoning designations were assigned or changed. Board Member Wilson asked if there were individual parcels of less than three acres that were combined. Planner Zollinger did not know, but stated they would have to go through

a Plat to combine Lots to create three acres. She confirmed that all of the other parcels surrounding these parcels were three acres or more. Board Member Wilson considered this to be a special circumstance.

Board Member Franklin commented that it appeared that the parcels surrounding the Applicants' parcels had a variety of different uses and zones, and because of that, she was torn on the special circumstance criterion. Board Member Armstrong felt that the Applicants did not meet the second criterion.

Chair Gezelius then addressed the third criterion, which was that the Variance must be granted for the owner to have essential enjoyment of their property as possessed by properties in the same zone. Board Member Armstrong offered that a Variance was necessary for the Applicants to have proper enjoyment and use of the land. Board Members Franklin, Wilson, and Stafsholt all concurred with Board Member Armstrong that this application met the third criterion.

The fourth criterion was whether the Variance would substantially affect the General Plan and would not be contrary to the public interest. Board Member Stafsholt was torn on this issue because this property was beyond where they have any improved roads, and it would be beyond what was already approved for Alice Claim. He stressed that they would also have to address new roads, new snow removal, new maintenance, and new infrastructure, which ultimately is paid for by the public. He stated that on one level, it was contrary to public interest. Open Space also surrounds the parcels on three sides, so there would be wildlife encroachment, as well as the Sensitive Land Overlay. He also noted the potential for fire would be increased. Board Member Stafsholt did not believe the application met the fourth criterion but was torn.

Board Member Wilson asked if there were City plans to complete the road. Mr. Frost explained it is private property and an easement was reserved when his clients deeded their interest in Alice Claim. It was anticipated to be a private drive maintained by the homeowners, and to the extent possible the Applicants would pay for installation costs, etc. so as not to burden the City.

Board Member Wilson assumed the proper Impact Fees would be paid for fire and other issues. She opined that this proposal did not affect the General Plan and she did not believe it was contrary to the public interest. The fact that Open Space surrounded the property would allow it to essentially maintain the three-acre requirement.

Board Member Franklin felt that both of the preceding comments raised great points. She appreciated the Applicants' position of staying within the Estate zoning requirements. She also respected how it was zoned on behalf of the public interest so they would not have HR-1 density in that area.

Board Member Armstrong did not find this to be any different than in any other neighborhood. She stated she resides in Aspen Springs, and they have a road that must

be plowed by the City due to the number of houses. She could not see that it was contrary to the public interest; rather, that was just the way it is in Park City. She opined that Applicants met the fourth criterion.

Chair Gezelius noted that the proposal would have a serious impact on the public. It would affect the visual Open Space, and it might or might not require avalanche mitigation. Additionally, because the land was in a heavy snow area, it might require a great deal of snow removal down a very narrow street. She stated that it would be extremely expensive to provide police, fire, sewer, storm drains, or general services to an isolated property. She felt it affected the general public to allow construction of anything on this substandard parcel.

Chair Gezelius next turned to the fifth criterion—that the spirit of the Land Management Code was observed, and substantial justice is done. Board Member Franklin felt this criterion was more difficult and noted that of all the issues they look at this is the largest gray area. She felt that all were looking at this with the spirit of the Land Management Code and best intent for the City and the community.

Board Member Armstrong opined that the request met the fifth criterion. Board Member Wilson also felt it met the fifth criterion. She noted the Land Management Code zoned this property as Estate, with the intention that parcels could be developed with homes. Since Open Space surrounded these parcels, they would have an area of approximately five acres with a single residence. When it came to substantial justice, Board Member Wilson felt that owning a family heirloom property that is essentially worthless is not just.

Board Member Stafsholt commented that a Variance would likely meet the spirit of the Land Management Code, so he felt this application met the fifth requirement.

Chair Gezelius stated the Board provided input on all five criteria and the Board must find that an application met all five in order to approve a Variance. She stated that Staff requested direction from the Board in terms of preparing Conditions of Approval and referenced page 19 of the Packet. The Board could deny the Variance and direct Staff to prepare Findings for a denial. They could also continue the discussion and request additional information on specific items. Chair Gezelius stated that there was varying input on the five criteria.

Board Member Wilson found the application to meet all five criteria and was inclined to approve the Variance. Chair Gezelius clarified that they cannot approve the Variance. The Board can only direct Staff to prepare an approval of the Variance.

Chair Gezelius felt that Board Member Wilson tentatively moved to direct Staff to prepare an approval of the Variance and asked if there was a second. There was no second. Chair Gezelius asked if there was a motion to direct Staff to deny the Variance. Board

Member Stafsholt stated his intention to move to direct Staff to deny the Variance based on Section 15-10-3, numbers (2) and (4).

Senior City Attorney, Mark Harrington made it clear that Board Member Stafsholt suggested that because special circumstances and the General Plan are two criteria where the Board does not meet a three-member consensus, then Staff would prepare Findings of Fact consistent with those members who did not feel those criteria were met. He added that if the Board was not clear on that, they could request more discussion on those two items prior to the vote. He felt the motion was appropriately made and the first order of business was whether it would get a second.

Board Member Stafsholt asked if he should move to direct Staff to deny the Variance instead of being specific. Mr. Harrington stated that Board Member Stafsholt appropriately referenced the specific criteria, and he wanted to make sure the Board was clear about the basis for the motion before a second or a request for more discussion.

Board Member Stafsholt mentioned that his motion was intended to cite the criteria related to special circumstances and contrary to the public interest. Chair Gezelius asked if there was a second to Board Member Stafsholt's motion. The motion died for lack of a second. Board Member Armstrong recommended another poll because Board Member Stafsholt's motion was based on two criteria that were not met. She did not agree that the two criteria were not met. Mr. Harrington noted that Board Member Franklin's position on three of the five criteria was unclear. He also recalled that for the special circumstances criteria, the poll was 1 -1-2, meaning one in favor, one undecided, and two against. He mentioned he did not count the Chair's position for this round. For the General Plan criteria, he recalled that the poll was 2 – 1 – 1. He suggested the Board have further discussion on these two criteria, and they might persuade Board Member Franklin to go one way or another, or they could consolidate the positions to see if they could reach a consensus. He added that as pointed out by Chair Gezelius, it would also be appropriate to request additional information that might help the Board decide those two issues.

Board Member Franklin referenced the special circumstances criteria and stated that the Applicants' Statement talked about surrounding land that appeared to not be developable. The two parcels adjacent to the subject parcels were identified as an Open Space parcel, while the other was a Non-Disturbance Area ("NDA") parcel. She noted they have had experience with land that should not have been disturbed having been disturbed. She requested clarification of the zoning and the two parcels referenced.

Mr. Frost pulled up the Alice Claim Plat and noted a small triangular section labeled Open Space, and the rest of that land was Mining Claims that belongs to Talisker Land Holding Company. He noted there was a corner on the west side of the road that was part of Open Space Parcel D of the Alice Claim Subdivision. The rest of that land was a Mining Claim owned by Talisker Land Holding Company.

Board Member Stafsholt stated it appeared the entire south border of the Lots represented as Alice Claim Open Space Parcel D was along the dirt road. Mr. Frost stated that it was all Open Space on the east side of the road. On the south side, there was a small triangular portion that likely belonged to the Alice Claim, and he suspected the developer dedicated it as Open Space because it was not buildable. He added that the bulk of the border on the south side was Mining Claim.

Board Member Wilson referenced her prior question on this and asked if the parcel to the north, labeled on the graphic with King Development Group, Lot 1 NDA, was required to be Open Space as part of the Alice Claim Development Agreement. She understood based on her prior questions that it was required to be dedicated Open Space as part of the Development Agreement.

Planner Zollinger presented the Plat. Mr. Harrington believed it referenced the King Road Subdivision, but it was still dedicated Open Space. Mr. Frost referenced the Alice Claim Plat and advised that was Lot 1, which was platted as NDA. He believed it was part of the Development Agreement, but it was not dedicated Open Space; rather, it was private land owned by Lot 1 and they could not build on that portion. He advised there was a designated Building Envelope, and the remainder was NDA. Board Member Stafsholt reported that when they revised the Alice Claim Subdivision, Lot 1 was 3.01 acres.

With regard to the prior comment that this Lot would be surrounded by Open Space, Chair Gezelius stated that this application was required to stand on its own with its substandard Lot size, and not rely on neighbors or zoning around it for additional space. The Board was required to only address the Applicants' specific parcel, and any limitations on house size or Setbacks would be the burden of this parcel and not adjacent parcels.

Chair Gezelius asked if Board Member Stafsholt wanted to reiterate the two criteria that he felt were not met and that formed the basis for his motion. Board Member Stafsholt expressed his belief that there were no special circumstances that did not apply to other properties in the same zone. He did not require any additional information for that criterion.

With regard to the public interest criteria, he did not feel a Variance would substantially affect the General Plan, other than setting a precedent; however, he felt it would be contrary to the public interest to extend a road that would end up being maintained at the public's cost. Because the parcels abut Open Space, he felt it would also affect wildlife and would increase fire danger as compared to what currently exists.

Chair Gezelius again asked if there was a second to Board Member Stafsholt's motion. There was no second.

Chair Gezelius stated that the Board is required to take action to continue, grant, or deny the application. Board Member Armstrong observed that the application could be denied if only one of the criteria was not met. Chair Gezelius confirmed that the application must

meet all five criteria to support granting the Variance. Board Member Armstrong suggested that if the motion were limited to the second criteria, she would second the motion, but was unsure that all would be in favor.

In response to an inquiry, Mr. Harrington stated that the motion must include specific findings as it relates to the criteria that were not met.

MOTION: Board Member Stafsholt moved to recommend Staff prepare documentation to DENY the Variance based on Criteria 2 – special circumstances attached to the property, set forth in Section 15-10-8.

Board Member Armstrong seconded the motion.

VOTE: Board Member Stafsholt-Aye; Board Member Armstrong-Aye; Board Member Franklin-Aye; Board Member Wilson-Nay. The motion passed 3-to-1.

Chair Gezelius reported that Staff was directed to prepare a denial of the Variance for consideration at a subsequent meeting. Mr. Harrington clarified that this vote was not considered Final Action, as Final Action was defined very narrowly. The Board provided Staff with direction to return with Findings, and once the Board votes on those Findings, that would be the Final Action. The Board reserved the right to change the vote until they vote on the Final Action Letter.

There was discussion about continuing this item to the next meeting on December 12, 2023. Chair Gezelius noted that in order to vote on this item, there would need to be a quorum comprised of those at this meeting. It was noted that Board Member Stafsholt would be unavailable for the December 12, 2023, meeting.

Chair Gezelius felt that fairness dictates that this item be continued to a meeting when the four Board Members present would be able to attend. Assistant Director Ward suggested continuing this item to a date uncertain, and they would re-notice for a date when they would have a quorum.

MOTION: Board Member Stafsholt moved to CONTINUE this item to a date uncertain. Board Member Armstrong seconded the motion.

VOTE: The motion passed with the unanimous consent of the Board.

2. ADJOURN

MOTION: Board Member Franklin moved to ADJOURN. Board Member Wilson seconded the motion.

VOTE: The motion passed with the unanimous consent of the Board.

Board of Adjustment Meeting
November 7, 2023

The Board of Adjustment Meeting adjourned at approximately 6:19 p.m.

Approved by _____
Ruth Gezelius, Board of Adjustment Chair

PENDING APPROVAL

Board of Adjustment Staff Report



Subject: 2724 Creek Drive
Application: PL-23-05853
Author: Jack Niedermeyer
Date: December 12, 2023
Type of Item: Variance

Recommendation

(I) Review the requested Variance to reduce the Front Setback for a Front-Facing Garage from 25 feet to 20 feet to allow for the extension of an existing Single-Family Dwelling garage at 2724 Creek Drive by seven-feet and six-inches, (II) conduct a public hearing, and (III) determine whether the Applicant meets the five criteria in Land Management Code [§ 15-10-8 Variance](#) and direct staff to prepare a Final Action Letter granting or denying the requested Variance for review on January 9, 2024.

Description

Applicant: Susan Shay, Owner
Alan Johnson, Applicant Representative
Location: 2724 Creek Drive
Zoning District: Single- Family
Adjacent Land Uses: Single Family Dwellings and Open Space
Reason for Review: Variance require Board of Adjustment approval.¹

LMC Land Management Code
SFD Single-Family Dwelling
SF Single-Family Zoning District

Terms that are capitalized as proper nouns throughout this staff report are defined in LMC [§ 15-15-1](#).

Background

2724 Creek Drive is Lot 1 of the McLeod Creek Subdivision, recorded with Summit County Recorder's Office in 1981. On January 22, 1987, the City Council adopted Ordinance No. 87-5 (Exhibit E), amending the Zoning Map to rezone the McLeod Creek Subdivision from Residential Development to Single-Family. In 1987, a Single-Family Dwelling (SFD) was constructed at 2724 Creek Drive.

¹ LMC [§ 15-1-8\(I\)](#)

2724 Creek Drive fronts both Creek Drive and Creek Court. Land Management Code (LMC) [§ 15-4-17](#) establishes setback requirements for unusual lot configurations and states development on corner Lots must have two front Setbacks, unless otherwise an exception in the LMC. There are no exceptions for corner Lots in LMC [Chapter 15-2.11 Single Family District](#); 2724 Creek Drive is therefore a corner Lot.

Land Management Code (LMC) [§ 15-2.11-3\(B\)\(3\)](#) establishes a 25-foot Front Setback for front-facing garages in the Single Family Zoning District. On July 17, 2023, the Applicant submitted a building permit application for an addition to the existing front-facing garage. Upon review of the submitted plans, Planning Staff notified the Applicant the proposed addition encroached into the required 25-foot Front Setback for front-facing garages.

On September 14, 2023, the Applicant submitted a Variance application requesting the following:

- Extending the garage 7 feet 6 inches to encroach five feet into the required 25-foot Front Setback for Front-Facing Garages to provide for additional space in the laundry room and two parking spaces in the garage.
- Constructing a rooftop deck above the proposed garage extension to encroach five feet into the required 25-foot Front Setback for Front-Facing Garages.

The image below is from the Applicant's submittal (Exhibit D), which displays the existing Single-Family Dwelling and garage:



Analysis

Pursuant to LMC [§ 15-10-8](#), the Board of Adjustment reviews Variance requests, holds a public hearing, and takes Final Action. In granting a Variance, the Board of Adjustment may impose additional requirements on the Applicant to (I) mitigate any harmful effects of the Variance or (II) serve the purpose of the standard or requirement that is waived or modified.²

As described above, 2724 Creek Drive fronts both Creek Drive and Creek Court. LMC [§ 15-4-17](#) establishes setback requirements for unusual lot configurations and states development on corner Lots must have two front Setbacks, unless otherwise an exception in the LMC. There are no exceptions for corner Lots in LMC [Chapter 15-2.11 Single Family District](#); 2724 Creek Drive is therefore a corner Lot.

For the Single-Family Zoning District, the LMC requires a minimum Front Setback of 20 feet for Main Buildings, and a Front Setback of 25 feet for Front-Facing Garages, measured from the Front Property Line.³

- (I) **The Applicant Requests a Variance to the 25-foot Front Setback requirement for Front Facing Garages found in Land Management Code [§ 15-2.11-3\(B\)\(3\) Front Setback Requirement for the Single-Family Zoning District](#).**

The Applicant requests a five-foot Variance from the Front Setback requirement for Front-Facing Garages, to reduce the Front Setback from 25 feet to 20 feet to expand the existing garage and rooftop deck by 7 feet 6 inches. The image below is from the Applicant's proposed plans (Exhibit C) which shows the location of the proposed garage and deck expansion:

² LMC [§ 15-10-8 \(H\)](#).

³ LMC [§ 15-2.11-3\(B\)\(3\)](#)

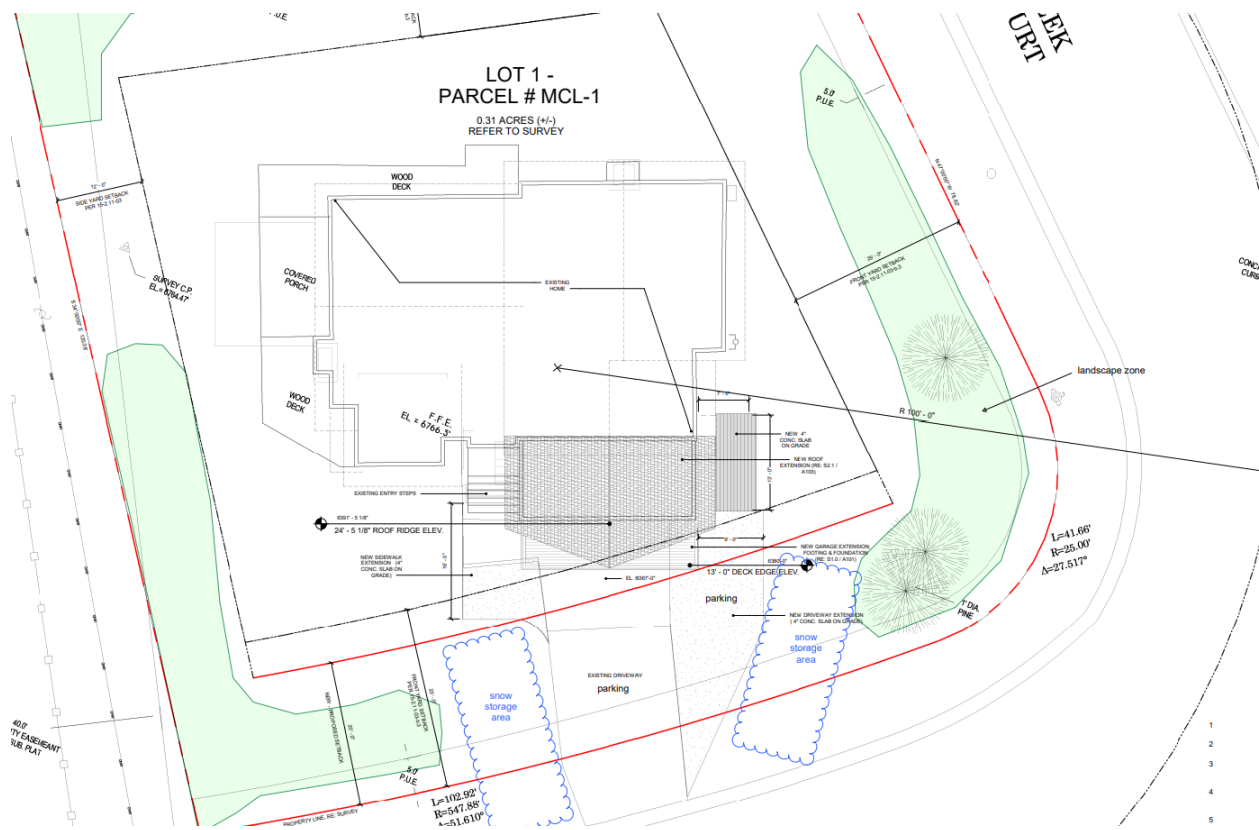

(II) The Applicant bears the burden of proving the five Variance Criteria in Land Management Code § 15-10-8(C) are met.

Upon review of the Applicant Statement that was submitted as part of the Variance Application, Planning Staff requested that the Applicant provide an updated statement which clearly addressed each of the five Variance Criteria. The original Applicant Narrative and updated email response are attached as Exhibit A.

The five criteria and Applicant’s response are outlined below:

Requirement	Analysis of Proposal
<p>1. Literal enforcement of the LMC would cause an unreasonable hardship for the Applicant that is not necessary to carry out the general purpose of the LMC.</p>	<p><u>Applicants Request:</u> The original home construction/layout is not consistent with current needs and expectations from a homeowner in this neighborhood. The two glaring deficiencies are: no laundry room and small primary bedroom with virtually no close space. These two deficiencies have a negative impact on both the quality of day-to-day life, as well as potential resale in the future.</p>

The only effective way to address these deficiencies is by expanding the garage by 7'6". Utilizing available room on Northwest and Southwest setbacks would not address the existing problems.

Staff Analysis:

As seen below, expansion of the existing SFD is achievable to the north, west, southwest, and southeast of the existing SFD.

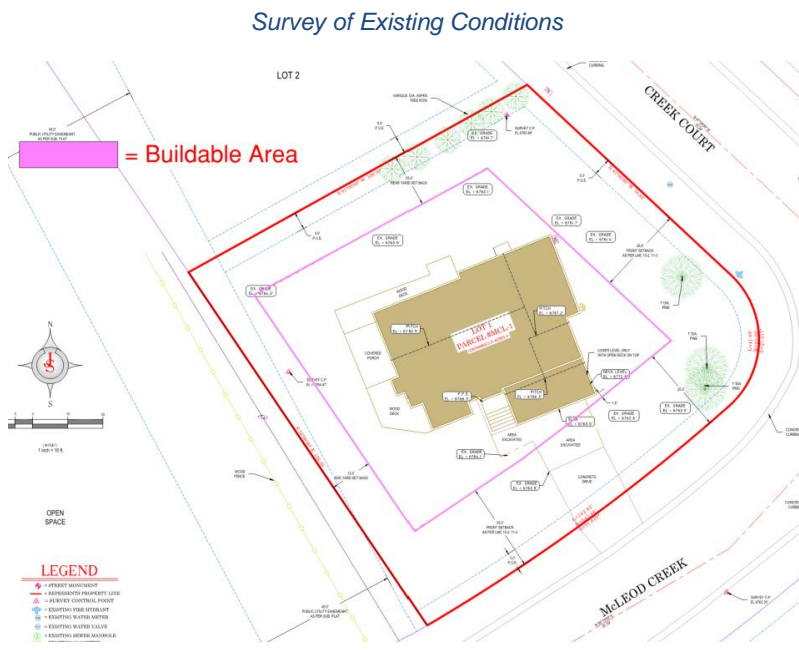

2. There are special circumstances attached to the Property that do not generally apply to other Properties in the same zone.

Applicants Request:

The home's footprint (for whatever reason) was originally positioned up against the setbacks in the Northeast and Southeast corners. **See attached site survey.

Also of note, the home does not sit parallel with the East/West North/South setback. It is twisted approximately 30% to the Southeast.

In other words, adding 7'6" to the existing garage would cross the existing setback in the Southeast corner. So, while approximately 70% of the proposed extension would fall inside the existing setback the Southeast corner would cross the setback line. Thus, the necessity

	of a variance.
--	----------------

Staff Analysis:

As outlined in the table below, each of the eight corner Lots within the McLeod Creek Subdivision were required to comply with the 25-foot Front Setback Requirement for Front-Facing Garages.

Lot Number	Analysis
<i>*Subject Property*</i>	<i>*Subject Property*</i>
<u>Lot 1 – 2724 Creek Drive</u> • Approved in 1987	Complies: The approved Site Plan displays two 25-foot Front Setbacks for the Front Facing Garage.
<u>Lot 5 – 2706 Creek Drive</u> • Approved in 1988	Complies: The approved Site Plan displays two 25’ Front Setbacks for the Front-Facing Garage.
<u>Lot 23 – 2418 Creek Drive</u> • Approved in 1994	Complies: The garage is positioned so that it is subject to only one of the two Front-Setback requirements.
<u>Lot 24 – 2419 Creek Drive</u> • Approved in 1997	Complies: The garage is positioned so that it is subject to only one of the two Front-Setback requirements.
<u>Lot 27 – 2471 Creek Drive</u> • Approved in 1989	Complies: The garage was approved at 35 feet from the property line abutting Creek Drive and at a distance of 30 feet from the property line that borders the turnaround to the north.
<u>Lot 28 – 2501 Creek Drive</u> • Approved in 1984	Complies: The garage is positioned so that it is subject to only one of the two Front-Setback requirements.
<u>Lot 37 – 2697 Creek Drive</u> • Approved in 1992	Complies: The approved site plan shows the SFD and Garage in a location that complies with the two 25-foot Front Setbacks.
<u>Lot 47 – 2731 Creek Drive</u> • Approved in 2005	Complies: The approved site plan was conditioned to comply with the 25-foot Front Setback requirement for Front Facing Garages.

3. Granting the Variance is essential to the enjoyment of a substantial Property right possessed by other Property in the same zone.

Applicants Request:
Our response to this question may sound redundant but essentially, we would benefit greatly on a day-to-day basis by having a ‘laundry room’. We would also benefit greatly by having primary bedroom storage. Presently, the closet is 5’x5’ (25 sf.) and can hold just 50% of 1 person’s clothes.

	<p><u>Staff Analysis</u></p> <p>Including 2724 Creek Drive (Lot 1), there are eight corner Lots within the McLeod Creek Subdivision - Lots 1, 5, 23, 24, 27,28, 37, and 47.</p> <p>At the time of building permit review, each of the eight corner Lots were required to comply with the Front-Setback requirement of 25 feet for new Front-Facing Garages.</p>
<p>4. The Variance will not substantially affect the General Plan and will not be contrary to the public interest.</p>	<p><u>Applicants Request:</u> This variance will have virtually no effect on the ‘general plan’ as only the Southeast corner would cross the existing setback. Additionally, this property is at the end of Creek Dr. (dead end) and only visible to one neighbor across the street.</p> <p><u>Staff Analysis:</u> 2724 Creek Drive is within the Park Meadows neighborhood, Neighborhood 2 of the Park City General Plan.</p> <p>Section 2.4 of Neighborhood 2 of the Park City General Plan states: <i>“To maintain the aesthetic of the individual pockets of development, limitations on building pads should be adopted”</i>.</p>
<p>5. The spirit of the LMC is observed, and substantial justice done.</p>	<p><u>Applicants Request:</u> In essence the variance is for a 6’x10’ corner wedge of approximately 30 sf. and would have an imperceptible visual impact and thus the spirit of the land management code will be maintained, and substantial justice done.</p> <p><u>Staff Analysis:</u></p> <p>The purposes of the SF Zoning District include the following:</p> <p><u>15-2.11-1 Purpose</u> The purpose of the Single-Family District is to:</p> <ul style="list-style-type: none"> • maintain existing predominately Single Family detached residential neighborhoods, • allow for Single Family Development Compatible

	<p>with existing Developments,</p> <ul style="list-style-type: none"> • maintain the character of mountain resort neighborhoods with Compatible residential design; and • require Streetscape design that minimizes impacts on existing residents and reduces architectural impacts of the automobile. <p>Per the Front Setback Requirements for the SF Zoning District, LMC § 15-2.11-3(B):</p> <ol style="list-style-type: none"> 1. In Thaynes Canyon Subdivision 1 and 2 and Prospector Village Subdivision, the minimum Front Setback for Main Buildings is twenty feet (20') and minimum Front Setback for Garages is ten feet (10'). 2. In Prospector Park Subdivisions 1, 2, and 3, the minimum Front Setback is 20 feet (20'), including Garages. 3. <u>In all other subdivisions</u>, the minimum Front Setback is twenty feet (20'). New Front-Facing Garages for Single Family and Duplex Dwellings must maintain a minimum of twenty-five feet (25') from Front Lot Line.
--	---

(III) The Development Review Committee met on November 21, 2023, and did not identify any issues related to district or utility development standards.⁴

Notice

Staff published notice on the City’s website and the Utah Public Notice website and posted notice to the property on November 22, 2023. Staff mailed courtesy notice to property owners within 300 feet on November 22, 2023. The *Park Record* published courtesy notice on November 28, 2023.⁵

Public Input

Staff did not receive any public input at the time this report was published.

Alternatives

⁴ The Development Review Committee meets the first and third Tuesday of each month to review and provide comments on Planning Applications, including review by the Building Department, Engineering Department, Sustainability Department, Transportation Planning Department, Code Enforcement, the City Attorney’s Office, Local Utilities including Rocky Mountain Power and Dominion Energy, the Park City Fire District, Public Works, Public Utilities, and the Snyderville Basin Water Reclamation District (SBWRD).

⁵ LMC § 15-1-21.

- The Board of Adjustment may direct staff to draft a Final Action Letter granting the Variance to reduce the Front Setback for Front-Facing Garages from 25 feet to 20 feet; or
- The Board of Adjustment may direct staff to draft a Final Action Letter denying the Variance to reduce the Front Setback for Front-Facing Garages from 25 feet to 20 feet; or
- The Board of Adjustment may request additional information and continue the discussion to January 9, 2024.

Exhibits

Exhibit A: Applicant Statement

Exhibit B: McLeod Creek Subdivision Plat

Exhibit C: Proposed Plans

Exhibit D: Site Images

Exhibit E: Ordinance No. 87-5

RECEIVED

SEP 14 2023

PARK CITY
PLANNING DEPT.

September 12, 2023

To Whom It May Concern,

Park City Planning/Building Department

In early July our request for a Building Permit was denied. The plan was designed based on our understanding that the community setbacks were 20 feet. After several go-arounds with Planning, we came to the realization that we were 'in fact' a corner lot and corner lot setbacks are actually 25'. Thus, our proposed garage extension of 7'6" would result in one corner of this extension crossing over the 25' setback line. (See site Plan 1).

Exacerbating the situation is the fact that the home is not oriented parallel with the entry street (Creek Dr.). The home is twisted to face the southeast with the northeast and southeast corners established almost on top of the setbacks. While there is ample room on the property for potential expansion, expansion into those areas would not address our needs.

Nature of Hardship:

The original layout of the home, while generally well designed, has some glaring flaws that negatively affect its functionality as a home in the 21st century. The interior storage and closet space being the primary problems.

- A. The master (primary) bedroom has 24 sf of storage (see pic). It can only hold half the clothing for one individual, who needs to use the closet of a guest bedroom for the balance of space. Partner #2 must use a downstairs guest bedroom for their cloths.
- B. There is no actual 'laundry room'. A washer and dryer are tucked into a hall closet opposite a guest bedroom and adjacent to the primary main floor bathroom and does not function well and is a source of congestion for normal daily traffic flow.
- C. The existing garage (though technically a 2-car garage) is undersized and as a result has never been able to hold 2 vehicles comfortably.

Granting a variance to a 20' setback would be a gamechanger for the function, use and enjoyment of this property in many ways.

- It would enable the garage to be extended 7'6" and would provide for the additional space for a laundry room, while providing adequate space for 2 vehicles (one of which could be a full-size vehicle in length).
- It would provide for a rooftop deck (over garage extension) as currently exists and integral to the function of the primary bedroom as well as maintain this important aesthetic design feature of the home.
- It would increase the primary bedroom size dramatically much of which would be dedicated to the necessary closet/storage space needed.
- Additionally, the small storage shed adjacent to the garage would ensure the garage could be used for vehicle storage. (Not lawnmowers, ladders, shovels, tools, garbage cans, etc.)

Summary – Getting a 5' setback variance approved would dramatically enhance the function and enjoyment of this property from several different vantage points. It would also bring the home up to an expected standard for the community for this day and age.

Susan has been a Park City resident for 35years, while I have been a 32-year resident. In this time, we have seen a huge transformation of our community in a very positive direction to the amazing place we all call home. We attribute much of Park City's progress to the work of the Planning and Building Departments. That said, we hope you will see the merit of our proposal and the positive impact it will have on our home and our lives in the unique community we live in.

We would also be happy to provide any testimonies from our neighbors with regards to this project. As neighbors, they have all seen the plans and have expressed their support as the aesthetics will enhance the neighborhood in a positive way.

Submitted by Alan Johnson-partner
on behalf of Susan Shay-owner

From: [Alan Johnson](#)
To: [Jack Niedermeyer](#); [Susan Shay](#)
Subject: [External] Fwd: Lot 1 Site Survey
Date: Monday, October 23, 2023 10:50:51 AM
Attachments: [Lot 1 Site Survey.pdf](#)

[CAUTION] This is an external email.

Jack,

I hope this answers all the questions appropriately. I condensed a lot of the original verbage to just basic answers as they apply specifically.

Please let me know if I need to add anything or modify anything.

Thanks again for your help.

Alan

----- Forwarded message -----

From: **Ptarmigan**
Date: Mon, Oct 23, 2023 at 10:39 AM
Subject: Lot 1 Site Survey
To: Alan Johnson

Alan-

Please see below:

Park City Planning Department
2724 Creek Drive - Variance Request
Attn: Jack Niedermeyer

10/23/23

1. The original home construction/layout is not consistent with current needs and expectations from a homeowner in this neighborhood. The two glaring deficiencies are: no laundry room and small primary bedroom with virtually no close space.

These two deficiencies have a negative impact on both the quality of day-to-day life, as well as potential resale in the future.

The only effective way to address these deficiencies is by expanding the garage by 7'6". Utilizing available room on Northwest and Southwest setbacks would not address the existing problems.

2. The home's footprint (for whatever reason) was originally positioned up against the setbacks in the Northeast and Southeast corners. **See attached site survey.

Also of note, the home does not sit parallel with the East/West North/South setback. It is twisted approximately 30% to the Southeast.

In other words, adding 7'6" to the existing garage would cross the existing setback in the Southeast corner. So, while approximately 70% of the proposed extension would fall inside the existing setback the Southeast corner would cross the setback line. Thus, the necessity of a variance.

3. Our response to this question may sound redundant but essentially, we would benefit greatly on a day-to-day basis by having a 'laundry room'.

We would also benefit greatly by having primary bedroom storage. Presently, the closet is 5'x5' (25 sf.) and can hold just 50% of 1 person's clothes.

4. This variance will have virtually no effect on the 'general plan' as only the Southeast corner would cross the existing setback. Additionally, this property is at the end of Creek Dr. (dead end) and only visible to one neighbor across the street.

In essence the variance is for a 6'x10' corner wedge of approximately 30 sf. and would have an imperceptible visual impact and thus the spirit of the land management cope will be maintained, and substantial justice done.

Ptarmigan Property Services, Inc.

LEGEND

- ① 50 FOOT WIDE NON-EXCLUSIVE UTILITIES AND DRAINAGE EASEMENT ALONG LOT LINES AS SHOWN.
- ② 10.0 FOOT WIDE NON-EXCLUSIVE UTILITIES AND DRAINAGE EASEMENT ALONG BACK LOT LINES AS SHOWN.
- ③ 400 FOOT WIDE NON-EXCLUSIVE UTILITIES EASEMENT.
- ④ 20.0 FOOT WIDE NON-EXCLUSIVE UTILITIES EASEMENT.

SURVEY MONUMENTS **FIRE HYDRANT** **N 89°58'59" W 1420.644'**

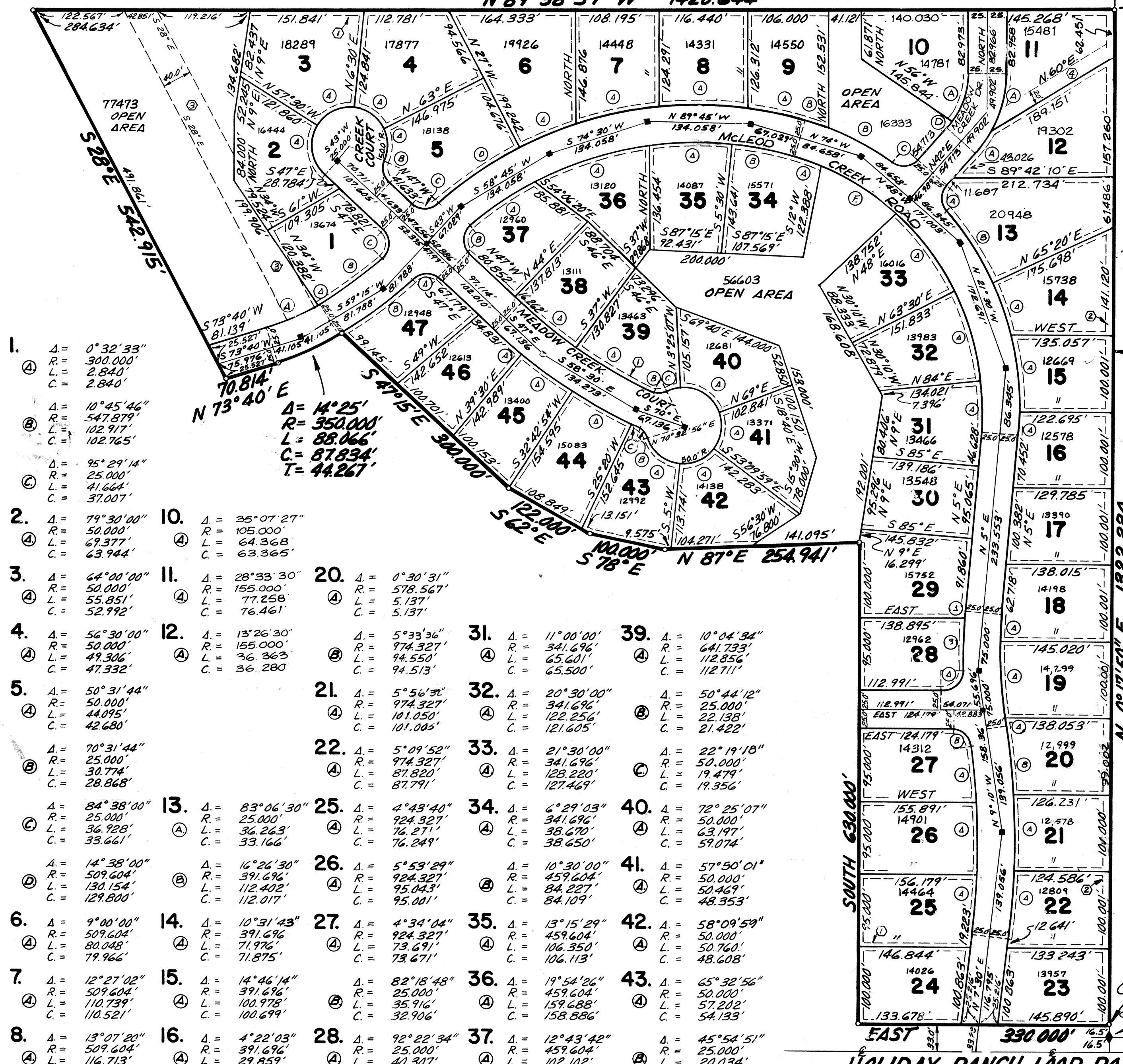

1. Δ = 0°32'33" R = 300.000' L = 2.640' C = 2.840'	10. Δ = 35°07'27" R = 105.000' L = 64.368' C = 63.365'	20. Δ = 0°30'31" R = 578.567' L = 5.137' C = 5.137'	30. Δ = 11°00'00" R = 341.696' L = 65.601' C = 65.500'	40. Δ = 72°25'07" R = 50.000' L = 63.197' C = 59.074'
2. Δ = 79°30'00" R = 50.000' L = 69.377' C = 63.944'	11. Δ = 28°33'30" R = 155.000' L = 77.258' C = 76.461'	21. Δ = 5°56'36" R = 974.327' L = 101.050' C = 101.003'	31. Δ = 10°04'34" R = 641.733' L = 112.856' C = 112.711'	41. Δ = 57°50'01" R = 50.000' L = 50.469' C = 48.353'
3. Δ = 24°00'00" R = 50.000' L = 55.851' C = 52.992'	12. Δ = 13°26'30" R = 155.000' L = 36.363' C = 36.280'	22. Δ = 5°09'52" R = 974.327' L = 87.820' C = 87.791'	32. Δ = 20°30'00" R = 25.000' L = 22.256' C = 21.422'	42. Δ = 58°09'59" R = 50.000' L = 50.760' C = 48.608'
4. Δ = 56°30'00" R = 50.000' L = 49.306' C = 47.332'	13. Δ = 83°06'30" R = 25.000' L = 36.263' C = 33.166'	23. Δ = 4°49'40" R = 924.327' L = 76.271' C = 76.249'	33. Δ = 21°30'00" R = 341.696' L = 123.220' C = 127.469'	43. Δ = 65°32'56" R = 50.000' L = 57.202' C = 54.133'
5. Δ = 50°31'44" R = 50.000' L = 44.095' C = 42.680'	14. Δ = 10°31'43" R = 391.696' L = 71.975' C = 71.875'	24. Δ = 4°34'04" R = 924.327' L = 73.691' C = 73.671'	34. Δ = 6°29'03" R = 341.696' L = 38.670' C = 38.650'	44. Δ = 7°22'54" R = 691.733' L = 42.256' C = 42.249'
6. Δ = 9°00'00" R = 509.604' L = 80.048' C = 79.966'	15. Δ = 14°46'14" R = 391.696' L = 100.978' C = 100.699'	25. Δ = 5°53'29" R = 924.327' L = 95.043' C = 95.101'	35. Δ = 13°15'29" R = 459.604' L = 106.350' C = 106.113'	45. Δ = 6°47'06" R = 691.733' L = 81.915' C = 81.868'
7. Δ = 12°27'02" R = 509.604' L = 110.739' C = 110.521'	16. Δ = 4°22'03" R = 391.696' L = 29.859' C = 29.852'	26. Δ = 82°18'48" R = 25.000' L = 35.916' C = 32.906'	36. Δ = 19°54'26" R = 459.604' L = 159.688' C = 158.886'	46. Δ = 3°30'00" R = 691.733' L = 42.256' C = 42.249'
8. Δ = 13°01'20" R = 509.604' L = 116.713' C = 116.458'	17. Δ = 4°22'03" R = 391.696' L = 29.859' C = 29.852'	27. Δ = 92°22'34" R = 25.000' L = 40.307' C = 36.081'	37. Δ = 12°43'42" R = 459.604' L = 102.102' C = 101.893'	47. Δ = 85°23'45" R = 25.000' L = 37.261' C = 33.907'
9. Δ = 8°25'38" R = 509.604' L = 74.953' C = 74.886'	18. Δ = 3°43'19" R = 578.567' L = 37.583' C = 37.577'	28. Δ = 6°17'24" R = 628.567' L = 69.004' C = 68.970'	38. Δ = 7°55'39" R = 459.604' L = 88.791' C = 88.729'	48. Δ = 14°03'48" R = 300.000' L = 72.645' C = 72.468'
19. Δ = 05°02'42" R = 391.696' L = 34.491' C = 34.479'	29. Δ = 1°05'10" R = 628.567' L = 11.915' C = 11.915'	39. Δ = 10°04'34" R = 641.733' L = 112.856' C = 112.711'	49. Δ = 19°30'57" R = 341.696' L = 116.386' C = 115.825'	

SURVEYOR'S CERTIFICATE

I JAMES G. WEST DO HEREBY CERTIFY THAT I AM A REGISTERED LAND SURVEYOR AND THAT I HOLD CERTIFICATE No. 3082 AS PRESCRIBED UNDER THE LAW OF THE STATE OF UTAH. I FURTHER CERTIFY THAT BY AUTHORITY OF THE OWNERS, I HAVE MADE A SURVEY OF THE TRACT OF LAND SHOWN ON THIS PLAT AND DESCRIBED BELOW AND HAVE SUBDIVIDED SAID TRACT OF LAND INTO LOTS AND STREETS, HEREAFTER TO BE KNOWN AS McLEOD CREEK SUBDIVISION AND THAT THE SAME HAS BEEN CORRECTLY SURVEYED AND STAKED ON THE GROUND AS SHOWN ON THIS PLAT.

DATE: Feb 18, 1980
 SURVEYOR: James G. West

OWNERS DEDICATION

KNOW ALL MEN BY THESE PRESENTS THAT WE THE UNDERSIGNED OWNERS OF THE HEREIN DESCRIBED TRACT OF LAND HAVING CAUSED SAME TO BE SUBDIVIDED INTO LOTS AND STREETS TO BE HEREAFTER KNOWN AS McLEOD CREEK SUBDIVISION DO HEREBY DEDICATE FOR PERPETUAL USE OF THE PUBLIC ALL PARCELS OF LAND SHOWN ON THIS PLAT AS INTENDED FOR PUBLIC USE. IN WITNESS WHEREOF WE HAVE HEREUNTO SET OUR HANDS THIS 27th DAY OF February A.D. 1980.

McLEOD CREEK ASSOCIATES
 UTAH POWER AND LIGHT CO.

ROBERT L. HARRINGTON
 J.C. TAYLOR, VICE PRESIDENT

ACKNOWLEDGMENT

STATE OF UTAH
 COUNTY OF SUMMIT

ON THIS 27th DAY OF February A.D. 1980 PERSONALLY APPEARED BEFORE ME THE UNDERSIGNED NOTARY PUBLIC IN AND FOR SAID STATE AND COUNTY, ROBERT L. HARRINGTON WHO AFTER BEING DULY SWORN, ACKNOWLEDGED TO ME THAT HE IS A GENERAL PARTNER OF McLEOD CREEK ASSOCIATES A UTAH PARTNERSHIP THAT HE SIGNED THE OWNER'S DEDICATION FREELY AND VOLUNTARILY FOR AND IN BEHALF OF SAID COMPANY FOR THE PURPOSES THEREIN MENTIONED AND THAT SAID COMPANY FOR THE PURPOSES THEREIN MENTIONED AND THAT SAID COMPANY EXECUTED THE SAME.

NOTARY PUBLIC: Carol Spencer
 My Commission Expires January 26, 1981
 Residing in Summit County, Utah

ACKNOWLEDGMENT

STATE OF UTAH
 COUNTY OF SUMMIT

ON THIS 27th DAY OF February A.D. 1980 PERSONALLY APPEARED BEFORE ME THE UNDERSIGNED NOTARY PUBLIC IN AND FOR SAID STATE AND COUNTY, J.C. TAYLOR WHO AFTER BEING DULY SWORN, ACKNOWLEDGED TO ME THAT HE IS A VICE PRESIDENT OF UTAH POWER AND LIGHT CO. A UTAH CORPORATION THAT HE SIGNED THE OWNER'S DEDICATION FREELY AND VOLUNTARILY FOR AND IN BEHALF OF SAID CORPORATION FOR THE PURPOSES THEREIN MENTIONED AND THAT SAID CORPORATION EXECUTED THE SAME.

NOTARY PUBLIC: Carol Spencer
 My Commission Expires January 26, 1981
 Residing in Summit County, Utah

McLeod Creek Subdivision

Located in the SE 1/4 of the SE 1/4 of Section 5, T.2S., R.4E., S.L.B.&M.

Prepared By: J.J. Johnson & Associates Civil Engineering Planning Surveying 1700 Park Avenue P.O. Box 1661 Park City, Utah 84060	City Planning Commission Approved & Accepted by the Park City Planning Commission this 27th Day of Feb A.D. 1980 Chairman: <i>Bernie Skatta</i>	Engineers Certificate Approved & Accepted by the Park City Engineering Department this 2nd Day of Oct A.D. 1980 Park City Engineer: <i>John Probasco</i>	Approval as to Form Approved as to Form this 19th Day of March A.D. 1981 Park City Attorney: <i>Michael J. McE</i>	Certificate of Attest Attest this 1st Day of April A.D. 1981 Park City Recorder: <i>M. R. Olson</i>	Council Approval & Acceptance Approved & Accepted by the Park City Council this 1st Day of April A.D. 1981 Mayor: <i>Ph. O. Green</i>	No. 178292 Recorded State of Utah, County of Summit, Recorded and Filed at the request of: <i>M. R. Olson - Park City Municipal Corp</i> Date <i>4-13-81</i> Time <i>2:10</i> Fee 33.50 Summit County Recorder: <i>Nevada Springs</i>
---	--	---	---	--	--	--

DRAWING TITLE
TOPOGRAPHIC SITE SURVEY

CLIENT CONTACT
SUSAN SHAY

2724 CREEK DRIVE
LOT 1 McLEOD CREEK SUBDIVISION
LOCATED WITHIN, SALT LAKE COUNTY, UTAH. A PART OF THE S.E. 1/4 SEC. 5, T. 2 S., R. 4 E. S.L.B.&M.

PROPERTY DESCRIPTION
 Lot 1 McLeod Creek Subdivision on file within the official records of Summit County, Utah. Containing 0.31 +/- Acres

SURVEYOR'S NARRATIVE

This Survey was performed at the request of Susan Shay For the purpose to locate spot elevations of the ground and existing home in relationship to the intended positioning of this lot. Also for the possible purpose of lot sales, future building addition and landscaping. Found monumentation have been tied, utilized on this survey. The elevation base is determined by the field G.P.S. Projection Based on Utah North NAD 1983 Projection then rounded off to the nearest 10 foot mark for a more efficient Bench Mark base. The project bench mark is 6760.00' = Found sewer manhole located at intersection at the frontage of this lot as shown.

NOTE:

1. Surveyor has made no investigation or independent search for easements of record encumbrances restrictive covenants ownership title evidence, or any other facts, conflicts, or discrepancies which may be disclosed by the details of a current title insurance policy.
2. See city and county planning, and zoning maps for information regarding setback, side yard, and rear yard instances as well as other building, use restrictions, and requirements.
3. Utility pipes, wires etc. may not be shown on this map, contractors builders and excavators shall verify the location of all existing utilities prior to construction, and/or excavation. Contact blue stakes and refer to utility maps for additional information.
4. Subdivision plat notes, pertaining to this lot and other restrictions obligations, convents etc. that may affect the design and use of this lot, see subdivision.
5. This is not a boundary survey, no corners have been set, this plat is intended for design review and approval purposes.

SURVEYOR'S CERTIFICATE

I, R. Shane Johanson, do hereby certify that I am a Professional Land Surveyor, holding certificate No. 7075114 as prescribed under the laws of the State of Utah. I further certify that by the owners' authority, I have made a survey of the tract of land shown on this plat and described hereon. The same has been correctly surveyed and referenced with ground measurements and other data as shown on this plat. This survey retraces lot/deed lines and may have corrected said lot/deed lines to coincide with found evidence and other interpolations and conclusions, based on said ground measurements, data surveys and other information and records. Furthermore, other unwritten rights of ownership or lines of occupation may have implied rights or may exist, and in conducting this survey and preparing this plat it is expressly understood that I do not warrant or certify any of those rights unless evidence and records of agreements or acts among the appropriate parties are provided to me sufficient to establish the existence and position of those lines.

REVISIONS:

REV #	DESCRIPTION	DATE

JOHANSON SURVEYING
 PROFESSIONAL LAND SURVEYORS
 SURVEY • DESIGN • SEPTIC • PLANNING

P.O. BOX 18941
 SALT LAKE CITY, UTAH 84118
 Shane Johanson P.L.S. 801-915-2541

COPYRIGHT
 This drawing is and at all times remains the exclusive property of Johanson Surveying shall not be used with out complete authorization and written support.

STAMP:

PROJECT NO.: S-23-090
 DATE: 8-18-2023
 DRAWN BY: BROCK T. CISNEROS
 OVERSEEN BY: SHANE R. JOHANSON P.L.S.
 SHEET NUMBER: SHEET-1



LEGEND

- = STREET MONUMENT
- = REPRESENTS PROPERTY LINE
- = SURVEY CONTROL POINT
- = EXISTING FIRE HYDRANT
- = EXISTING WATER METER
- = EXISTING WATER VALVE
- = EXISTING SEWER MANHOLE
- = EXISTING GAS METER
- = ELECTRIC METER
- = EXISTING TRANSFORMER
- = EXISTING UTILITY POLE
- = OVER HEAD UTILITY WIRES
- = WOOD/VINYL FENCE
- = EXISTING TREE

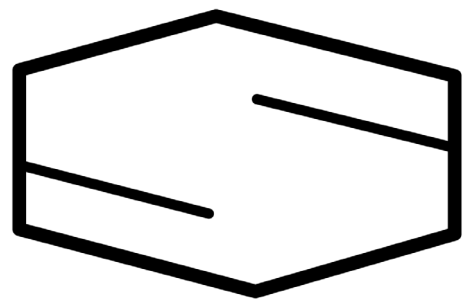

stereotomic
architecture + design

LIC.# 10151161-0301

jarrett moe, aia

1641 PHEASANT WAY
PARK CITY UT 84098
435-640-6850

JARRETT.MOE@GMAIL.COM

COPYRIGHT 2022 JARRETT J MOE
ALL RIGHTS RESERVED

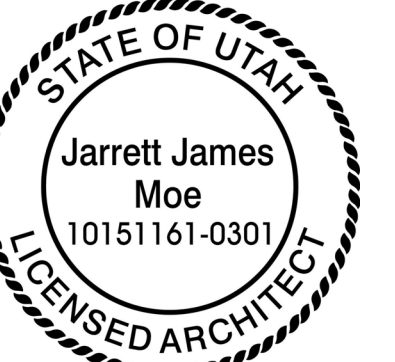

10.17.2023

CONSULTANT

Shay Residence Addition

Construction drawings 10/17/2023

2724 Creek Dr.
Park City, UT 84060

REVISIONS

#	DATE	DESCRIPTION
3	10/17/2023	Revision 3

KEYNOTES

- CONSTRUCTION PARKING / TRAFFIC MAY NOT BLOCK THE STREET WITHOUT A PERMIT FROM THE GOVERNING JURISDICTION
- MUD TRACKED ONTO THE STREET MUST BE CLEANED PRIOR TO THE END OF THE WORK DAY
- THE CONSTRUCTION SITE MUST BE MAINTAINED IN A NEAT AND CLEANLY MANNER. TRASH AND OTHER DEBRIS MAN NOT ACCUMULATE OUTSIDE ANY DUMPSTER
- AN ELEVATION CERTIFICATE IS REQUIRED WHEN THE PARCEL / LOT HAS AN AVERAGE GRADE GREATER THAN 5% AND / OR STRUCTURE HIGH EXCEEDS 25' MEASURED FROM EXISTING GRADE TO RIDGELINE
- REFER TO SIGNED, SEALED TOPOGRAPHIC SURVEY FOR EXACT LOCATION OF PROPERTY BOUNDARIES, EASEMENTS, EXISTING VEGETATION AND EXISTING TOPOGRAPHIC ELEVATIONS
- REFER TO CONSTRUCTION MITIGATION PLAN FOR DETAILS/NOTES REGARDING SWPPP AND CONSTRUCTION PROTECTION PROCEDURES



SITE / GRADING LEGEND

- NEW TOPOGRAPHY GRADING, MAJOR
- NEW TOPOGRAPHY GRADING, MINOR
- EXISTING TOPOGRAPHY CONTOURS, MINOR
- EXISTING TOPOGRAPHY CONTOURS, MAJOR
- EROSION CONTROL BLANKETS (SWPPP)
- SILT FENCE (SWPPP)
- STRAW WATTLE (SWPPP)
- LIMIT OF DISTURBANCE
- LANDSCAPE ROCK / RETAINING
- PROPERTY
- DRAINAGE DIRECTION

1 SITE PLAN

SCALE: 1/8" = 1'-0"

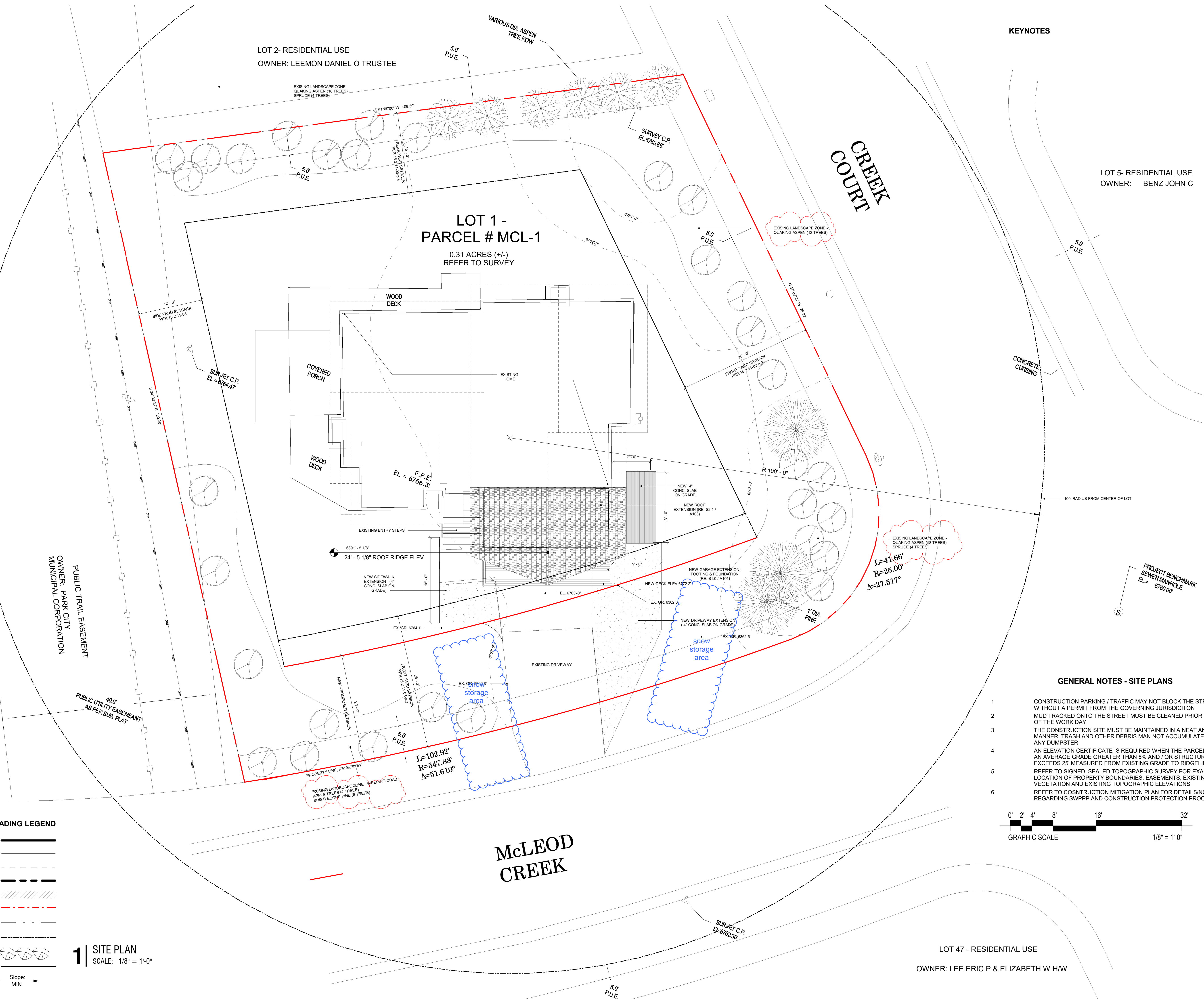

ARCHITECTURAL SITE PLAN

SHEET NO. A 011

JOB NO. 21300X

ORIGINAL SIZE 24"x36" IF ALTERNATE SHEET SIZE, SCALE REDUCED ACCORDINGLY

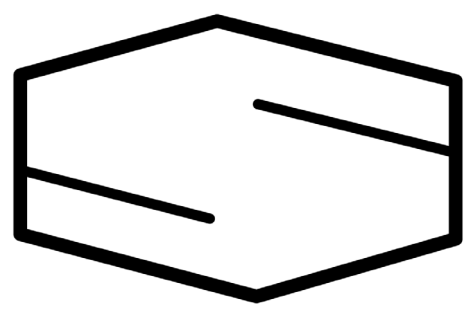

stereotomic
architecture + design

LIC.# 10151161-0301

jarrett moe, aia

1641 PHEASANT WAY
PARK CITY UT 84098
435-640-6850

JARRETT.MOE@GMAIL.COM

COPYRIGHT 2022 JARRETT J MOE
ALL RIGHTS RESERVED

CONSULTANT

Shay Residence Addition

Construction drawings 09/12/2023

2724 Creek Dr.
Park City, UT 84060

REVISIONS

#	DATE	DESCRIPTION
---	------	-------------

- EXISTING TO REMAIN
- - - EXISTING TO BE DEMOLISHED
- NEW CONSTRUCTION

KEYNOTES

- 3.16 NEW 4" S.O.G. ACCESSORY PARKING STALL
- 6.11 WOOD COLUMN PER STRUCTURAL

GEN NOTES FLOOR PLANS

- ALL DIMENSIONS ARE TO FACE OF STUD IN NEW CONSTRUCTION, FACE OF FINISH IN EXISTING.
- ALL FLOOR FINISH CHANGES OCCUR AT CENTERLINE OF DOOR IN CLOSED POSITION, UNLESS NOTED OTHERWISE.
- COORDINATE LOCATIONS OF ALL FLOOR AND ROOF DRAINS WITH PLUMBING PLANS.
- FOR FINISHES SEE ROOM FINISH PLAN AND SCHEDULE.

LEVEL 01 FLOOR PLAN

SHEET NO.

A 101

JOB NO. 21.XXXX

ORIGINAL SIZE 24"X36" IF ALTERNATE SHEET
SIZE, SCALE REDUCED ACCORDINGLY

Page 32 of 42

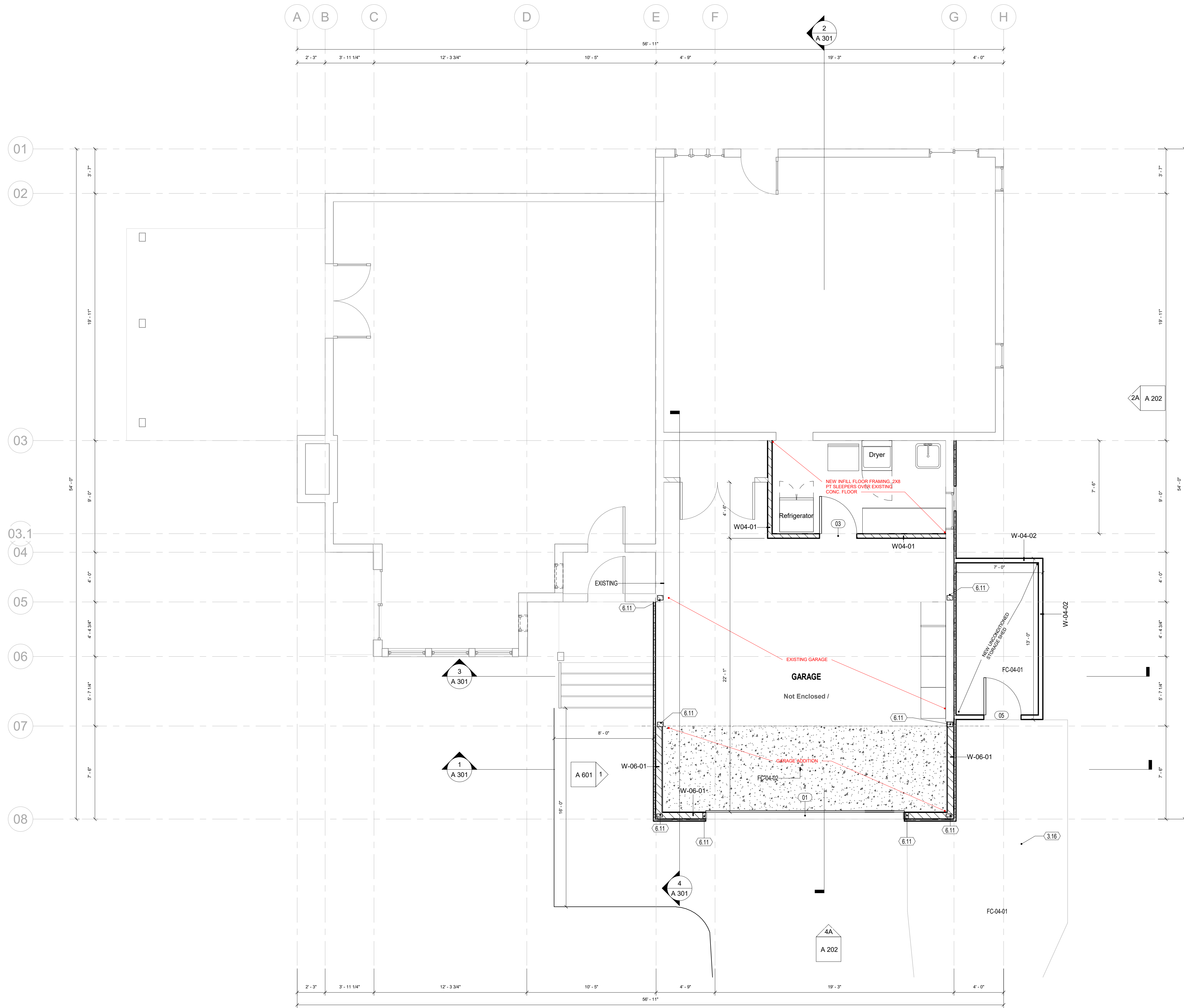

4A Living lvl
SCALE: 1/4" = 1'-0"

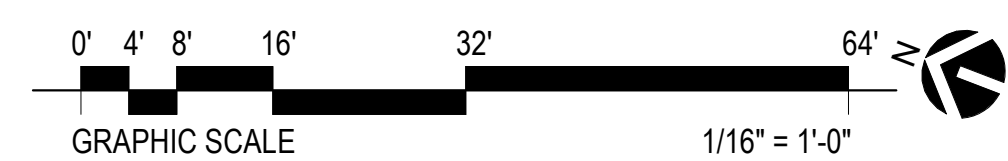

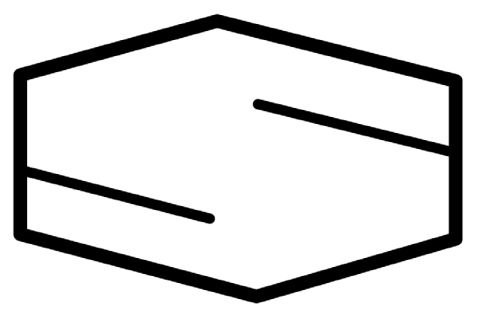

stereotomic
architecture + design

LIC.# 10151161-0301

jarrett moe, aia

1641 PHEASANT WAY
PARK CITY UT 84098
435-640-6850

JARRETT.MOE@GMAIL.COM

COPYRIGHT 2022 JARRETT J MOE
ALL RIGHTS RESERVED

CONSULTANT

Shay Residence Addition

Construction drawings 09/12/2023

2724 Creek Dr.
Park City, UT 84060

REVISIONS

#	DATE	DESCRIPTION
---	------	-------------

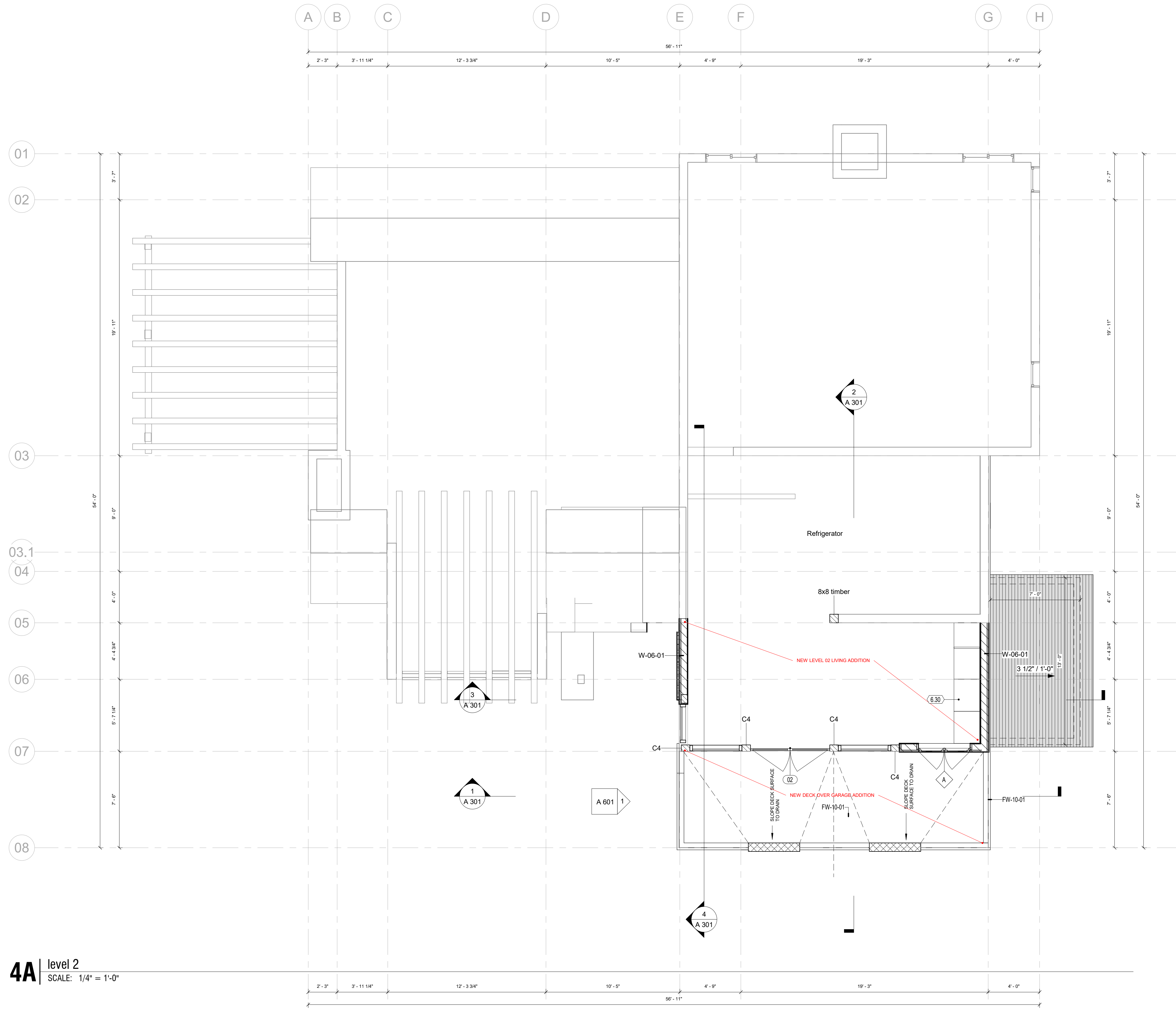

- EXISTING TO REMAIN
- - - EXISTING TO BE DEMOLISHED
- NEW CONSTRUCTION

KEYNOTES

6.30 FLOOR TO CEILING MILLWORK PER OWNER

GEN NOTES FLOOR PLANS

- ALL DIMENSIONS ARE TO FACE OF STUD IN NEW CONSTRUCTION, FACE OF FINISH IN EXISTING.
- ALL FLOOR FINISH CHANGES OCCUR AT CENTERLINE OF DOOR IN CLOSED POSITION, UNLESS NOTED OTHERWISE.
- COORDINATE LOCATIONS OF ALL FLOOR AND ROOF DRAINS WITH PLUMBING PLANS.
- FOR FINISHES SEE ROOM FINISH PLAN AND SCHEDULE.

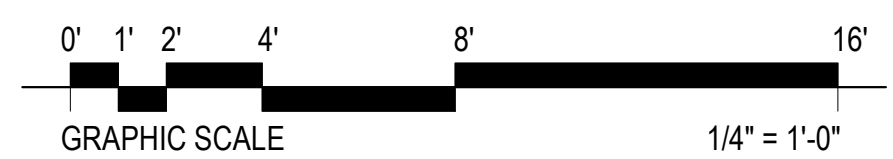

4A | level 2
SCALE: 1/4" = 1'-0"

LEVEL 02 FLOOR PLAN

SHEET NO.

A 102

JOB NO. 21.XXXXX

ORIGINAL SIZE 24"X36" IF ALTERNATE SHEET SIZE, SCALE REDUCED ACCORDINGLY

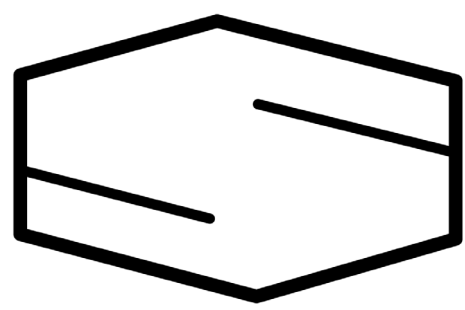

stereotomic
architecture + design

LIC.# 10151161-0301

jarrett moe, aia

1641 PHEASANT WAY
PARK CITY UT 84098
435-640-6850

JARRETT.MOE@GMAIL.COM

COPYRIGHT 2022 JARRETT J MOE
ALL RIGHTS RESERVED

CONSULTANT

Shay Residence Addition



Construction drawings 09/12/2023

2724 Creek Dr.
Park City, UT 84060

REVISIONS

#	DATE	DESCRIPTION
---	------	-------------

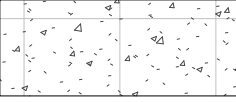
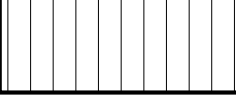
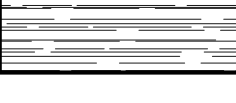
MATERIAL LEGEND

-  C - 01 / CONCRETE
-  FCS-01 / FIBER CEMENT VERTICAL SIDING
-  NS -01 / NATURAL STONE VENEER
-  ST-01 / STUCCO FINISH SYSTEM
-  AS-01 / ASPHALT SHINGLES

GENERAL NOTES - ROOF PLAN

- 1 GENERAL CONTRACTOR SHALL FIELD VERIFY ALL CONDITIONS AND SHALL REPORT TO THE ARCHITECT ANY UNKNOWN CONDITIONS, ERRORS, OR CONFLICTS IN THE DRAWINGS BEFORE BEGINNING WORK
- 2 DO NOT SCALE DRAWINGS
- 3 CRICKET AT ALL MECHANICAL ITEMS, SKYLIGHTS, ROOF HATCHES; 1/4" PER FOOT BACKSLOPE MINIMUM
- 4 SEE BUILDING AND WALL SECTIONS FOR ADDITIONAL ROOF DETAILS; SEE SHEET SERIES AES500 FOR ROOF ASSEMBLY CONSTRUCTION
- 5 ROOF/OVERFLOW DRAIN LOCATIONS SHOWN ARE APPROXIMATE; EXACT LOCATIONS SHALL BE DETERMINED IN FIELD. ROOF/OVERFLOW DRAINS TO BE PLACED TO ONE SIDE OF STRUCTURAL ELEMENT (IF EXISTS) AND INSTALLED AT LOWEST POINT
- 6 ALL GIVEN DECK BEARING POINTS ARE AT GRID LINE LOCATIONS UNLESS NOTED OTHERWISE

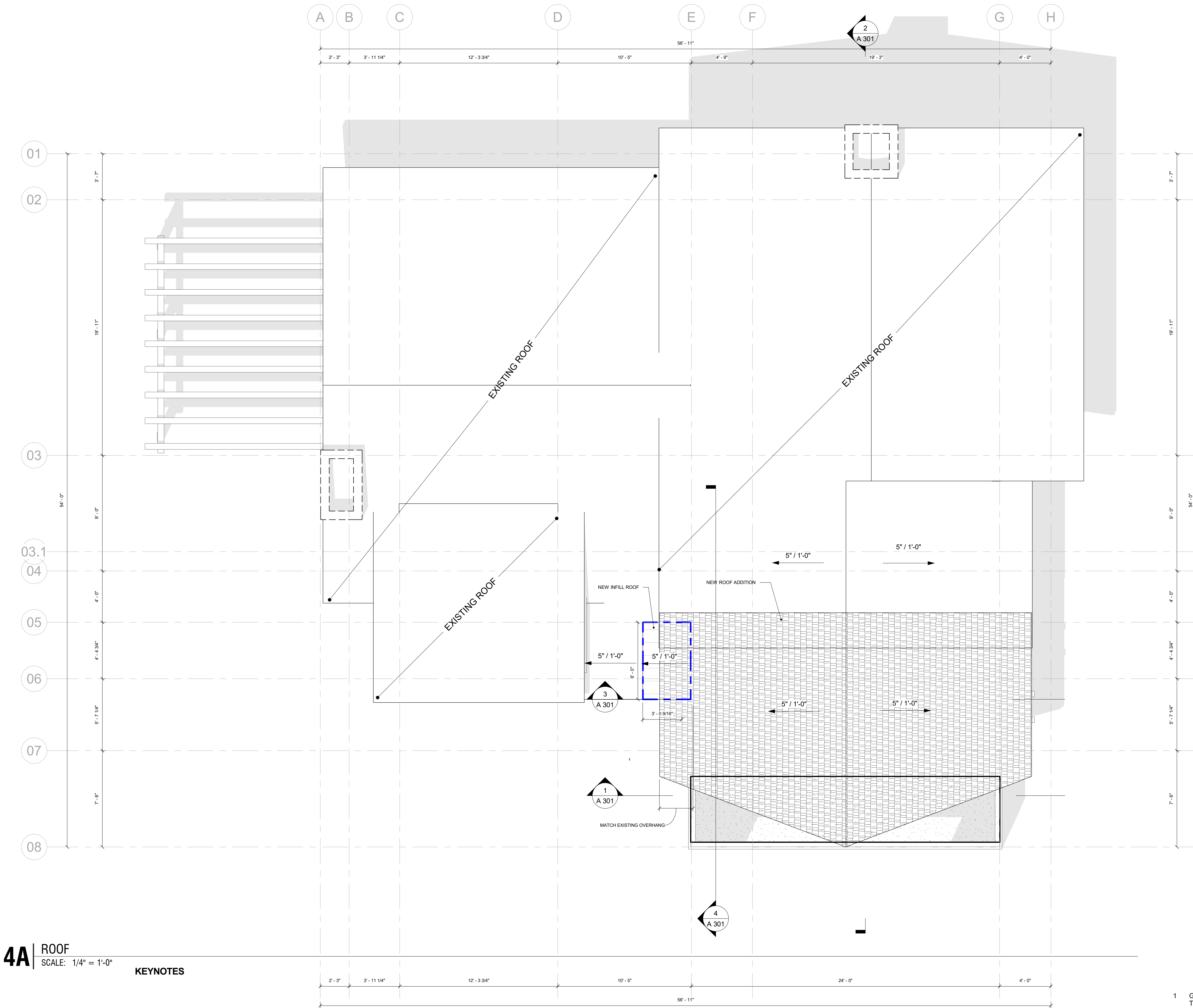
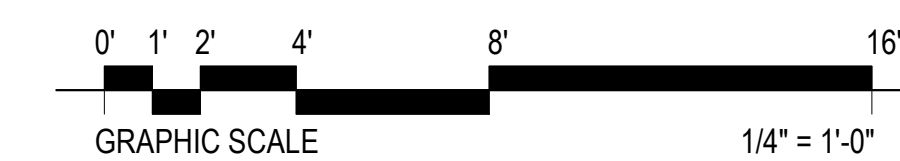

4A | ROOF
SCALE: 1/4" = 1'-0"

KEYNOTES

ROOF PLAN

SHEET NO.

A 103

JOB NO. 21.XXXXX

ORIGINAL SIZE 24"x36" IF ALTERNATE SHEET
SIZE, SCALE REDUCED ACCORDINGLY

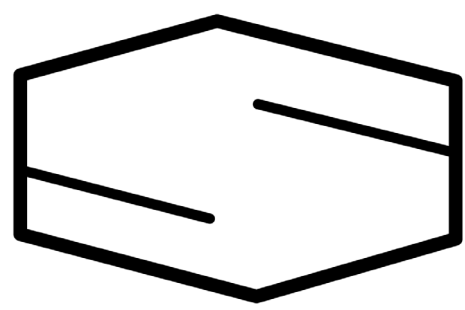

stereotomic
architecture + design

LIC.# 10151161-0301

jarrett moe, aia

1641 PHEASANT WAY
PARK CITY UT 84098
435-640-6850

JARRETT.MOE@GMAIL.COM

COPYRIGHT 2022 JARRETT J MOE
ALL RIGHTS RESERVED

CONSULTANT

Shay Residence Addition





Construction drawings 09/12/2023

2724 Creek Dr.
Park City, UT 84060

REVISIONS

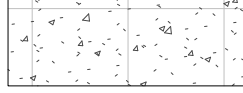
DATE DESCRIPTION

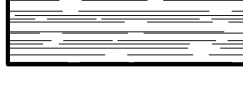
MATERIAL LEGEND

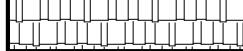
-  C - 01 / CONCRETE
-  FCS-01 / FIBER CEMENT VERTICAL SIDING
-  NS -01 / NATURAL STONE VENEER
-  ST-01 / STUCCO FINISH SYSTEM
-  AS-01 / ASPHALT SHINGLES

- EXISTING TO REMAIN
- EXISTING TO BE DEMOLISHED
- NEW CONSTRUCTION

KEYNOTES

EXTERIOR ELEVATIONS

SHEET NO.

A 201

JOB NO. 21.XXXXX

ORIGINAL SIZE 24"x36" IF ALTERNATE SHEET
SIZE, SCALE REDUCED ACCORDINGLY

Page 35 of 42

2A NEW WEST ELEVATION
SCALE: 1/4" = 1'-0"

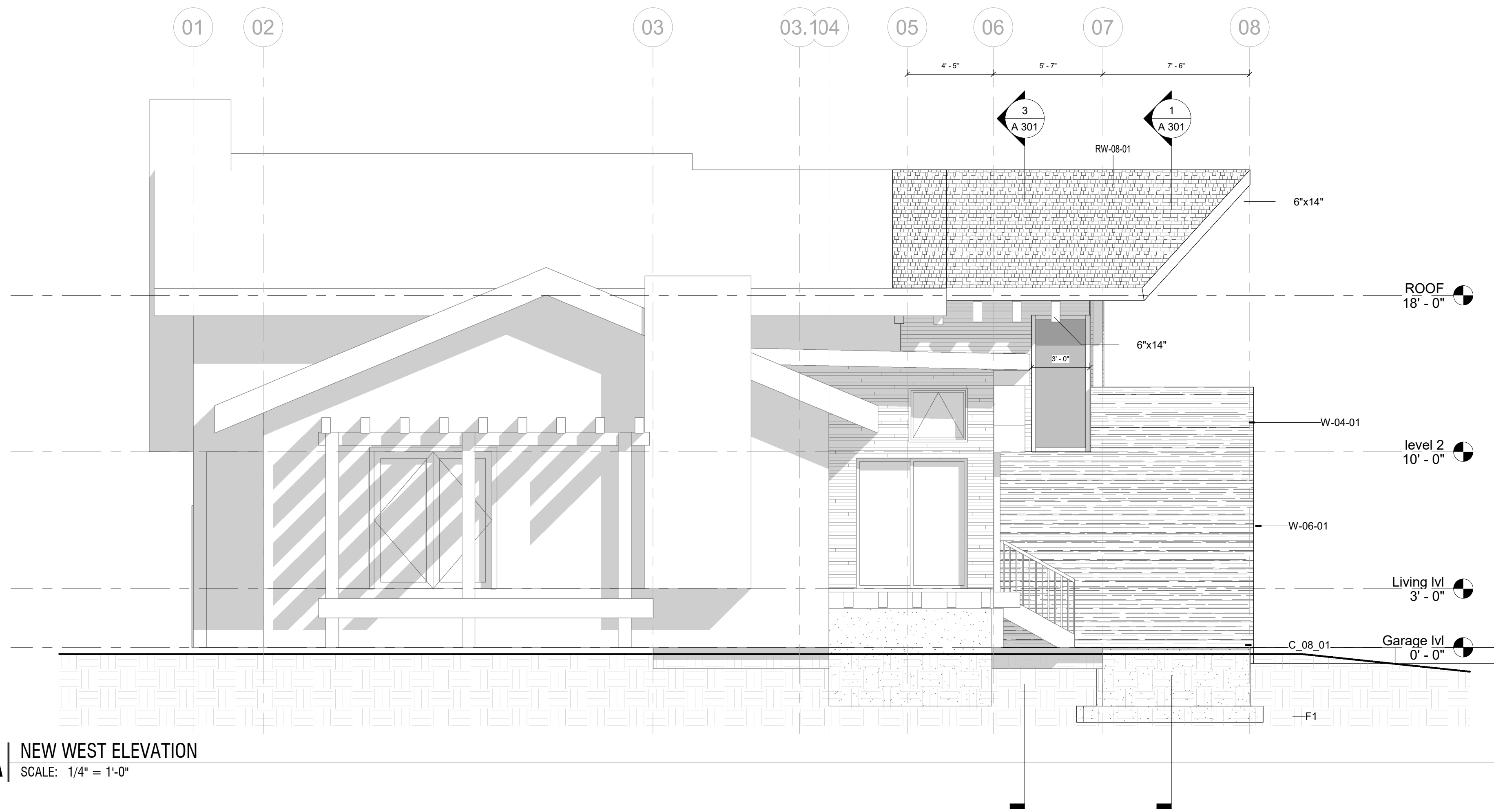

4A NEW NORTH ELEVATION
SCALE: 1/4" = 1'-0"

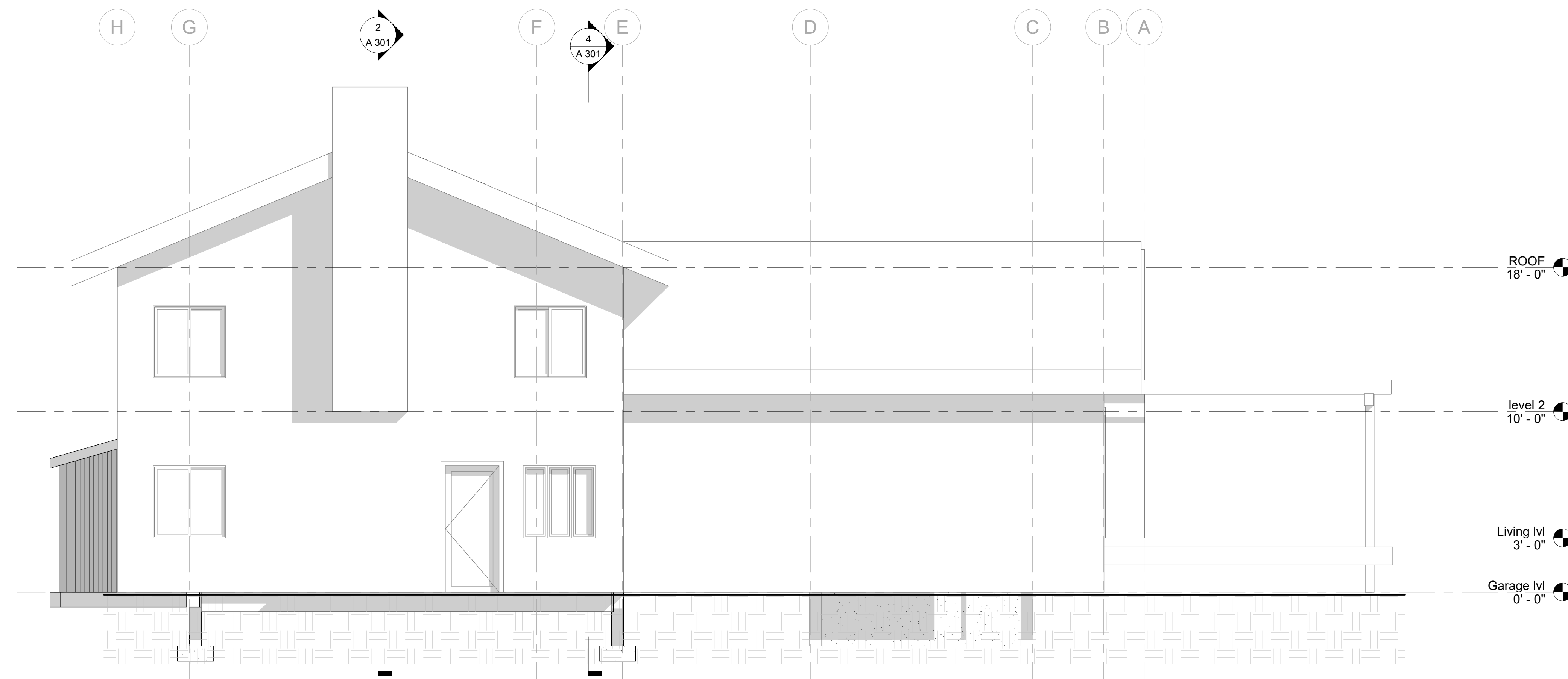

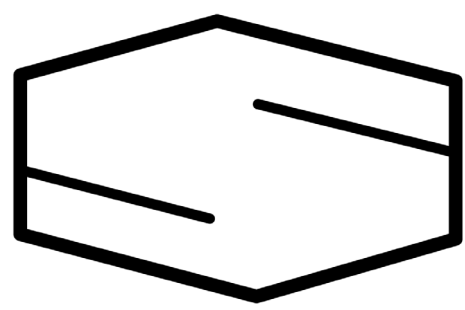

stereotomic
architecture + design

LIC.# 10151161-0301

jarrett moe, aia

1641 PHEASANT WAY
PARK CITY UT 84098
435-640-6850

JARRETT.MOE@GMAIL.COM

COPYRIGHT 2022 JARRETT J MOE
ALL RIGHTS RESERVED

CONSULTANT

Shay Residence Addition

Construction drawings 09/12/2023

2724 Creek Dr.
Park City, UT 84060

REVISIONS

#	DATE	DESCRIPTION
---	------	-------------

MATERIAL LEGEND

- C - 01 / CONCRETE
- FCS-01 / FIBER CEMENT VERTICAL SIDING
- NS - 01 / NATURAL STONE VENEER
- ST-01 / STUCCO FINISH SYSTEM
- AS-01 / ASPHALT SHINGLES

- EXISTING TO REMAIN
- EXISTING TO BE DEMOLISHED
- NEW CONSTRUCTION

KEYNOTES

DEMO LEGEND
SCALE: 3/4" = 1'-0"

EXTERIOR ELEVATIONS

SHEET NO.

A 202

JOB NO. 21.XXXXX

ORIGINAL SIZE 24"x36" IF ALTERNATE SHEET
SIZE, SCALE REDUCED ACCORDINGLY

Page 36 of 42

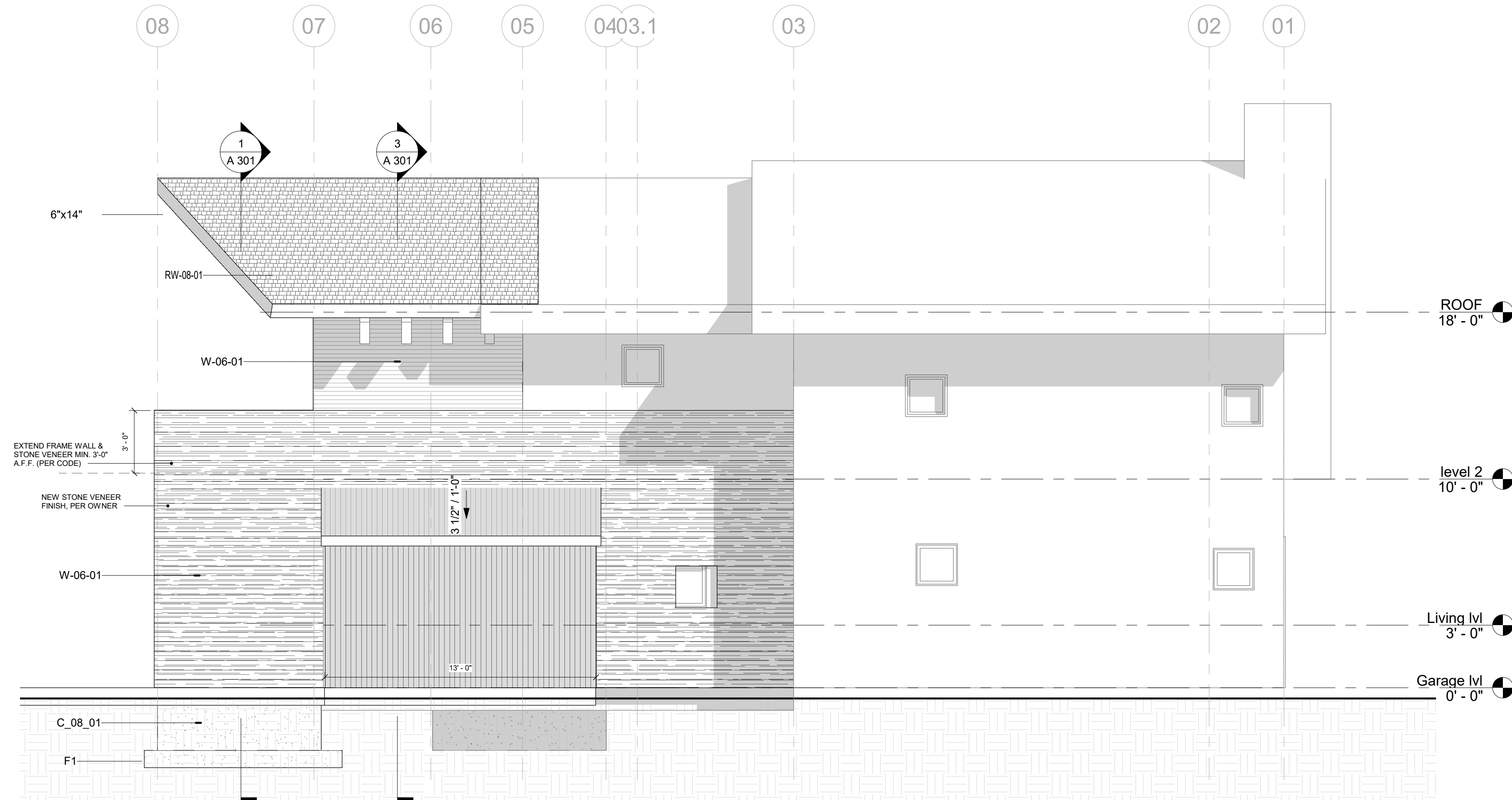

2A NEW EAST ELEVATION
SCALE: 1/4" = 1'-0"

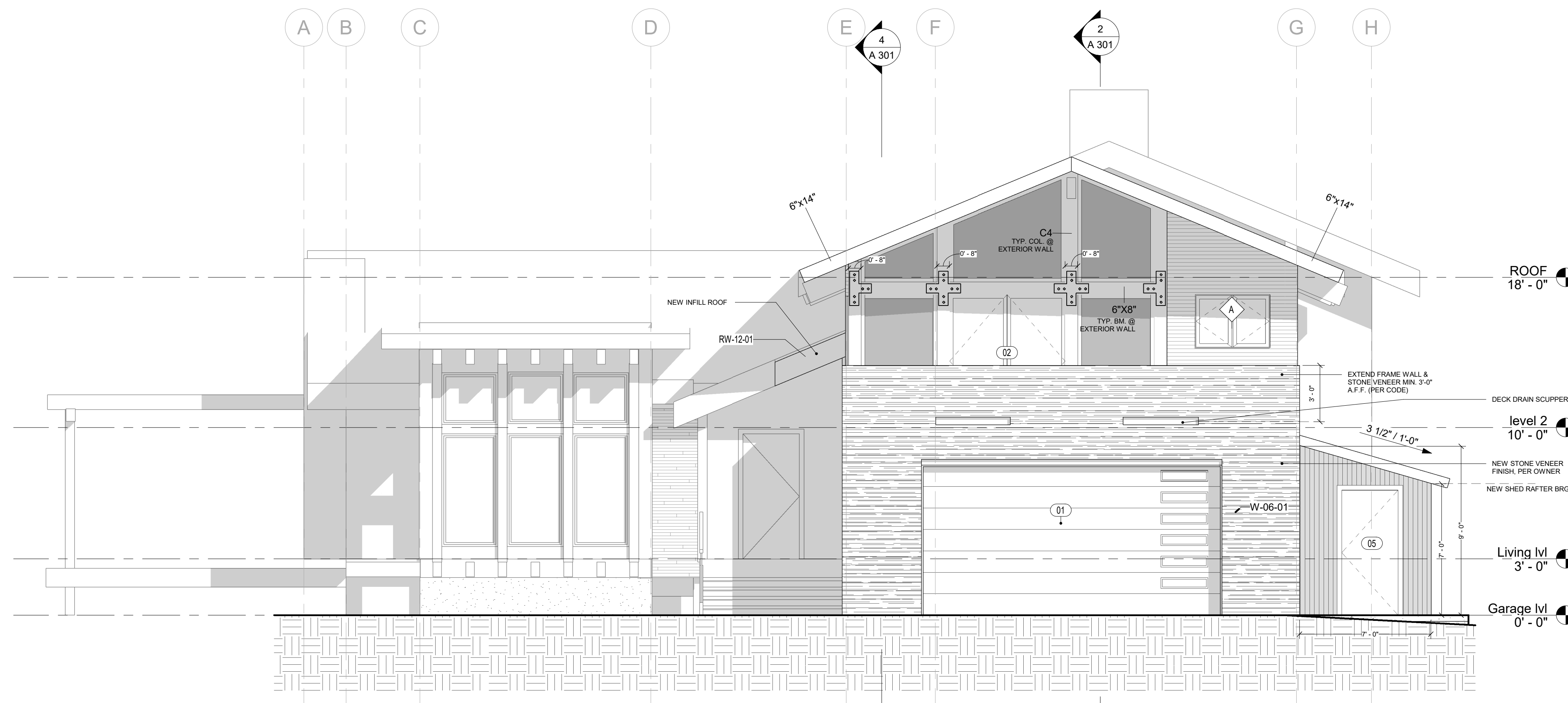

4A NEW SOUTH ELEVATION
SCALE: 1/4" = 1'-0"











Meadow Creek Ct.

Cree

ORDINANCE

AN ORDINANCE AMENDING THE OFFICIAL ZONING MAP OF
PARK CITY, UTAH TO INCLUDE THE MC LEOD CREEK SUBDIVISION
SINGLE FAMILY (SF) ZONE

WHEREAS, the City Council created the Single Family Zone to be designated to areas which are primarily permanent single family residential in character; and

WHEREAS, the McLeod Creek Subdivision is similar in nature to the other subdivisions designated as single family;

NOW, THEREFORE BE IT ORDAINED by the City Council of Park City as follows:

SECTION 1. ZONING MAP AMENDED. The zoning map of Park City is hereby officially amended to designate the McLeod Creek Subdivision as Single Family (SF) from its former designation as Residential Development (RD).

SECTION 2. EFFECTIVE DATE. This Ordinance shall become effective immediately upon publication.

PASSED AND ADOPTED this 22nd day of January, 1987.

PARK CITY MUNICIPAL CORPORATION

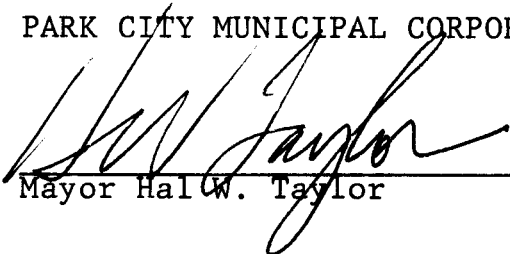

Mayor Hal W. Taylor

Attest:



City Recorder